

SIEMENS



RDE100..

en Programmable Room
Thermostat

fr Thermostat d'ambiance
programmable

el Προγραμματιζόμενος
θερμοστάτη χώρου

hu Programozható
Szobatermosztát

da Programmerbar
Rumtermostat

nl Programmeerbare
Kamerthermostaat

lt Programuojamas kambario
termostatas

pl Termostat programowalny

de Programmierbare
Raumthermostat

it Termostato
Programmabile

cs Programovatelný pokojový
termostat

es Termostato de ambiente
programable

tr Programlanabilir Oda
Termostati

zh 房间温控器

fi Ohjelmoitava
huonetermostaatti







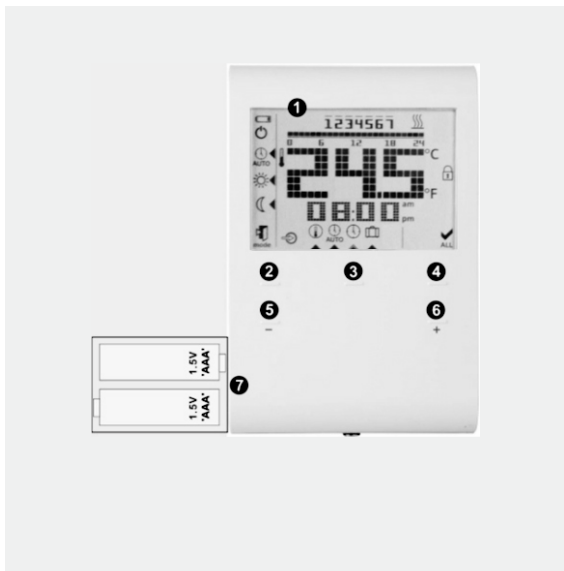







en Operating Instructions

RDE100.. – the room thermostat that allows you to set the ideal room temperature at the time you want.

There are several switching patterns available that can be set to your specific needs.

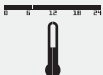

1. Display

	Indicating that batteries need to be replaced		
	(only with battery-powered version)		Digits for time
	Frost protection (heating) is active	am	Morning: 12-hour format
		pm	Afternoon: 12-hour format
	Auto Timer mode		Confirmation
AUTO	View and set Auto time switch	ALL	
	Comfort mode	°F	Room temperature in degrees Fahrenheit
	Economy mode	°C	Room temperature in degrees Celsius
	Escape		Button lock activated
mode		245	Display of room temperature, setpoint, etc.
	External input enabled		Heating ON
	Permanent setpoint setting	Weekday	
	Day and time setting	1 = Monday	
		7 = Sunday	
	Holiday mode setting	Timer bar	
			Current room temperature

2. Change operating mode

3. Set

4. OK

5. Decrease value

6. Increase value

7. Battery holder

Do you want to adjust the time and day?

set	Proceed as follows: <ul style="list-style-type: none"> • Press set and select  • Press ok and the time flashes for setting • Press + or - to adjust the time • Press ok to confirm • The weekday flashes, press + or - to select the desired day • Press ok to save the value • Press mode to exit or wait for the program to exit automatically
ok	
+	
-	
mode	





Do you want to lock the buttons?

mode	Press and hold mode for at least 7 seconds to activate a button lock. Repeat to unlock. The unit operates normally when the buttons are locked, but no changes are possible while the buttons are locked.
-------------	---

Are your rooms too warm/too cold?

+	Press + or - to increase or decrease the room temperature setpoint in increments of 0.5 °C / 1 °F. Proceed as follows: <ul style="list-style-type: none"> • Press + or - to adjust the setpoint temporarily. This adjustment is reset as soon as the operating mode changes. • Press ok, set or mode to save the value or wait for the program to exit automatically • To lock the setpoints, use parameters P06 and P08.
-	
ok	
set	
mode	

EN Do you want to change the operating mode?

mode	<p>The thermostat provides Comfort mode, Economy mode, and Auto mode. Changeover between the operating modes can be made manually by pressing mode.</p> <p> Comfort mode is the permanent (24 h) selection of Comfort. Select this mode to maintain Comfort temperature permanently without any time switch. It is used during occupancy periods, for example.</p> <p> Economy mode is the permanent (24 h) selection of Economy. Select this mode to maintain the Economy temperature permanently without any time switch. It is used during non-occupancy periods, for example at night.</p> <p> AUTO In Auto timer mode, operating modes (Comfort, Economy) are changed automatically according to the time switch set.</p> <p>! Note: Frost protection is a function always active in the background. As soon the room temperature falls below 5 °C, the unit automatically activates the heating .</p>
-------------	---



Do you want to set permanent temperature setpoints?

set ok + - mode !	<ul style="list-style-type: none">• Press set and select • Press ok to confirm• Press mode to select an operating mode, Comfort or Economy• Press + or - to adjust the setpoint permanently.• Press ok to confirm• Press mode to exit or wait for the program to exit automatically <p>Note: This permanent setpoint is used during Auto timer mode.</p>
--	---

Energy saving tips without sacrificing comfort

- Select Auto timer mode during the heating period, and set the time switch according to your normal habits at home
- Select Economy mode or Holiday mode for long periods of non-occupancy and during summer period

Do you want to set your Holiday mode?

<p>set ok + - mode</p>	<p>Use the Holiday mode to set the thermostat to a constant temperature while absent.</p> <ul style="list-style-type: none"> • Press set and select  • Press ok to confirm • Press + or - to adjust the temperature setpoint • Press ok to confirm • Press + or - to adjust the number of days for holidays (Note: 0 = Holiday mode OFF) • Press ok to save the value • When Holiday mode is activated, the remaining days are displayed on the screen
<p>!</p>	<p>Note: If you press mode while Holiday mode is active, the function is turned off and the  symbol disappears.</p> <p>If the Comfort and Economy setpoint values are both locked, the lowest locked setpoint value is the Holiday mode setpoint value. You can adjust the setpoint temperature from 5 °C up to the lowest locked setpoint value.</p>

EN Do you want to enter your own time switch?

Option 1: Time switch with individual day selection (P11=0)

set
ok
+
-
mode

You can select Comfort mode or Economy mode at 15 minute intervals throughout the day. The 0:00 to 24:00 hour time bar allows you to set the operating mode for the selected day(s).

Example:

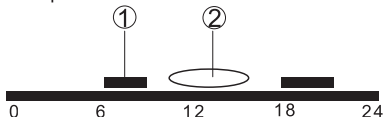

- ① Visible bars: Control to Comfort temperature
- ② Invisible bars: Control to Economy temperature

When Auto timer mode is enabled, changeover between the operating modes is automatic after the settings are saved.

Proceed as follows:

- 1) Press **set** and select  AUTO.
- 2) Press **ok** to confirm.
- 3) Time switch for day Mon(1) is displayed.
- 4) Press **+** or **-** to select the day, from Mon(1) to Sun(7).
- 5) Press **ok** to confirm the selection and initiate time programming.

During programming step:

- 6) Press **mode** to select an operating mode, (Comfort or Economy) **or**
- 7) Press **+** or **-** to adjust the time setpoint by 15 minutes for the selected mode.
- 8) Press **ok** to save the time switch.
- 9) Repeat steps 4-8 for all remaining days (if required);
or
- 10) Press **mode** or wait for the program to exit automatically.

Option 2: Time switch with the same 7 day selection (P11=1)

EN

set
ok
+
-
mode

You can set all the 7 day time switches at the same time.

Example:

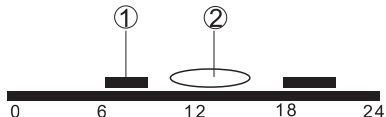

① Visible bars: Control to Comfort temperature

② Invisible bars: Control to Economy temperature

Proceed as follows:

- 1) Set the parameter (P11=1). Please refer to the section "**Do you want to change parameters**".
- 2) Press **set** and select  AUTO.
- 3) Press **ok** to confirm.
- 4) Time switch for period Mon (1) - Sun (7) is displayed.
- 5) Press **ok** to initiate time programming.

During programming step:

- 6) Press **mode** to select an operating mode, (Comfort or Economy) **or**
- 7) Press **+** or **-** to adjust time setpoint by 15 minutes for the selected mode.
- 8) Press **ok** to save the time switch.
- 9) Press **mode** or wait for the program to exit automatically.

Option 3: Time switch with 5-2 day selection (P11=2)

set
ok
+
-
mode

You can set Monday - Friday time switch at once and Saturday - Sunday time switch at once.

Example:

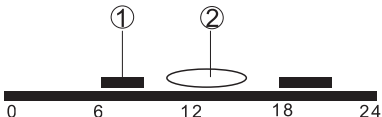

- ① Visible bars: Control to Comfort temperature
- ② Invisible bars: Control to Economy temperature

Proceed as follows:

- 1) Set the parameter (P11=2). Please refer to the section "**Do you want to change parameters**".
- 2) Press **set** and select  AUTO.
- 3) Press **ok** to confirm.
- 4) Time switch for period Mon(1) - Fri(5) is displayed.
- 5) Press **+** or **-** to select the period, Mon (1) - Fri (5) or Sat (6) - Sun (7).
- 6) Press **ok** to confirm the selected period and initiate time programming.

During programming step:

- 7) Press **mode** to select an operating mode, (Comfort or Economy) **or**
- 8) Press **+** or **-** to adjust the time setpoint by 15 minutes for the selected mode.
- 9) Press **ok** to save the time switch.
- 10) Repeat the steps 5-9 for the other period if necessary; or
- 11) Press **mode** or wait for the program to exit automatically.

Factory default for 7-day time switch

Default value	Day/s	Comfort mode	Economy mode
	Mo (1) – Fr (5)	6:00 – 8:00 hr 17:00 – 22:00 hr	22:00 – 6:00 hr 8:00 – 17:00 hr
	Sa (6) – Su (7)	7:00 – 22:00 hr	22:00 – 7:00 hr

Does symbol appear on the display? (Only with battery-powered versions)

Symbol  is displayed when the batteries are low. Replace them with 2 new alkaline batteries type AAA. Proceed as follows:

- Get 2 new alkaline batteries type AAA
- Remove the battery holder, then the batteries, insert the new batteries and, within 1.5 minutes, replace the battery holder
- Ensure the exhausted batteries are disposed of correctly, in compliance with environmental requirements

Do you want to change the parameters?

<p>+ – ok mod e</p>	<p>If you want to change control parameters, proceed as follows:</p> <ul style="list-style-type: none"> • Press + and – simultaneously for 5 seconds • Release them and parameter "P01" is displayed on the bottom segment • Press + or – to scroll to the parameter that needs to be adjusted • Press ok to select this parameter • Press + or – to adjust the value • Press ok to confirm the adjusted value • Press mode to exit the parameters without saving or wait for the program to exit automatically
--	---

Parameter list

Parameter no.	Description	Setting range (default)
P01	Time format	1 = 24:00 hours (default) 2 = 12:00 AM/PM
P02	Selection of °C or °F	1 = °C (default) 2 = °F
P03	Standard temperature display	1 = room temperature (default) 2 = setpoint
P04	Temperature sensor calibration	-3...3 °C Step 0.5 °C (-6...6 °F, step 1 °F) Default: 0 °C
P06	Comfort setpoint lock	0 = OFF (default) 1 = ON → locked according to setting in permanent temperature setpoint
P08	Economy setpoint lock	0 = OFF (default) 1 = ON → locked according to setting in permanent temperature setpoint
P09	Buzzer	0 = OFF 1 = ON (default)
P10	Show frost protection icon	0 = OFF (default) 1 = ON
P11	Time switch type for auto timer	0 = Individual Days (default) 1 = All 7 days 2 = 5/2 days
P12	Periodic pump run	0 = OFF (default) 1 = ON

P14	X1 External input (only for RDE100.1)	0 = No input 1 = External sensor 2 = Digital Input
P15	Temperature limitation (only for RDE100.1)	0 = OFF (default) 1 = ON
P16	Max limitation temperature for underfloor heating (only for RDE100.1)	25...60 °C, step 1 °C or 77...140 °F, step 1 °F Default: 30 °C
P17	Window contact features (only for RDE 100.1)	0 = Normally Open Contact (default) 1 = Normally Closed Contact
P21	Button scanning rate for the capacitive buttons (RDE100.1 only) Note: a shorter scanning rate means shorter battery life.	0.2 = 0.25 s 0.5 = 0.5 s 1.0 = 1.0 s (default) 1.5 = 1.5 s
P22	Reload factory settings	0 = OFF (default) 1 = reload
P23	Software version information	No adjustment possible
P78	Control behavior	0 = On/Off, 1.0K 1 = On/Off, 0.3K 2 = TPI fast 3 = TPI medium 4 = TPI slow (default)
P89	Forward shift on max	0, 0.5,...24 h Default: 0 h
P90	Early shutdown max	0, 0.5,...6 h Default: 0 h



The device is considered an electronics device for disposal in terms of European Directive 2012/19/EU and may not be disposed of as domestic garbage.

















- Dispose of the device through channels provided for this purpose.
- Comply with all local and currently applicable laws and regulations.
- Dispose of empty batteries in designated collection points.

de Bedienungsanleitung

RDE100.. – der Raumthermostat, mit dem Sie zu der von Ihnen gewünschten Zeit die ideale Raumtemperatur einstellen können. Verschiedene Schaltmuster können auf Ihre spezifischen Bedürfnisse angepasst werden.



1. Anzeige

	Anzeige, dass Batterien ersetzt werden müssen (nur Batterieversion)		Zeitanzeige
	Frostschutz (Heizen) ist aktiv	am pm	Morgen: 12-Stundenformat Nachmittag: 12-Stundenformat
	Auto-Timer-Betrieb		Eingangsbestätigung
AUTO	Anzeige und Einstellen des Auto Timer-Programms	ALL	
	Komfortbetrieb	°F	Raumtemperatur in Grad Fahrenheit
	Economy-Betrieb	°C	Raumtemperatur in Grad Celsius
	Zurück zu Normalbetrieb		Tastensperre aktiv
mode		245	Anzeige von Raumtemperatur, Sollwert etc.
	Externer Eingang freigegeben		Heizung Ein
	Permanente Sollwerteinstellung	1 2 3 4 5 6 7	Wochentag 1 = Montag 7 = Sonntag
	Einstellung für Tag und Uhrzeit		Timer-Balken
	Einstellung Ferienbetrieb		Aktuelle Raumtemperatur

2. Betriebsart ändern (mode)

3. Einstellen (set)

4. OK

5. Wert senken

6. Wert erhöhen

7. Batteriehalterung

Möchten Sie den Tag und die Uhrzeit einstellen?

set	Gehen Sie dabei wie folgt vor:
ok	<ul style="list-style-type: none"> • Set drücken und 🕒 wählen.
+	<ul style="list-style-type: none"> • ok drücken; die Zeit beginnt zu blinken.
-	<ul style="list-style-type: none"> • Drücken Sie + oder -, um die Zeit anzupassen.
mode	<ul style="list-style-type: none"> • ok zur Bestätigung drücken. • Der Wochentag blinkt; drücken Sie + oder - und wählen Sie den gewünschten Tag. • Mit ok speichern Sie den Wert. • mode drücken, um die Zeiteinstellung zu verlassen oder warten Sie kurz, bis das Programm wieder die normale Anzeige zeigt.





Möchten Sie die Tasten sperren?

mode	<p>Drücken Sie die Taste mode für min. 7 Sekunden. Dies aktiviert die Tastensperre.</p> <p>Verfahren Sie gleich, um die Tasten zu entsperren.</p> <p>Das Gerät arbeitet normal weiter, wenn die Tasten gesperrt sind; aber es können keine Änderungen vorgenommen werden.</p>
-------------	--

Sind Ihre Räume zu warm/zu kalt?

+	<p>Drücken Sie + oder -, um den Raumtemperatur-Sollwert um jeweils 0.5 °C/1 °F erhöhen oder senken. Gehen Sie wie folgt vor:</p> <ul style="list-style-type: none"> • Drücken Sie + oder -, um den Sollwert vorübergehend zu ändern. Diese Änderung wird bei der nächsten Betriebsartenänderung zurückgesetzt. • Drücken Sie ok, set oder mode, um sofort zu speichern, oder warten Sie kurz, bis das Programm ihn automatisch übernimmt. • Die Sollwerte können auch gesperrt werden über die Parameter P06 und P08.
-	
ok	
set	
mode	

Möchten Sie die Betriebsart ändern?

mode	<p>Der Thermostat bietet Komfortbetrieb ,</p> <p>Economy-Betrieb , Auto Timer-Betrieb  AUTO.</p> <p>Die Umschaltung zwischen den Betriebsarten erfolgt manuell durch Drücken der Taste mode.</p> <p>Komfortbetrieb bedeutet dauernden Komfortbetrieb (24 Stunden). Wählen Sie diese Betriebsart, wenn Sie im Raum dauernd Komforttemperatur wünschen. Sie ist die Raumtemperatur für die Belegungszeiten.</p> <p>Economy-Betrieb bedeutet dauernden Economy-Betrieb (24 Stunden). Wählen Sie diese Betriebsart, wenn Sie im Raum dauernd die Economy-Temperatur wünschen. Sie ist die Raumtemperatur für die Nichtbelegungszeiten, z.B. während der Nacht.</p> <p>Auto Timer-Betrieb bietet die Möglichkeit der automatischen Betriebsartenumschaltung (Komfort, Economy) nach Zeitprogramm.</p> <p>Hinweis:</p> <p>! Die Funktion Frostschutz ist im Hintergrund immer aktiv. Fällt die Raumtemperatur unter 5 °C, schaltet das Gerät automatisch die Heizung ein .</p>
-------------	---

Möchten Sie permanente Temperatursollwerte eingeben?

set ok + - mode	<ul style="list-style-type: none"> • Set drücken und  wählen. • ok zur Bestätigung drücken. • mode für die Betriebsartenauswahl drücken; Komfort oder Economy. • Drücken Sie + oder -, um den Sollwert permanent zu ändern. • ok zur Bestätigung drücken. • Drücken Sie mode, um die Eingabe ohne Speichern zu verlassen oder warten Sie kurz, bis das Programm wieder die normale Anzeige zeigt.
--	---





Hinweis: Der permanente Sollwert wird für den Auto-Timer-Betrieb verwendet.



Tipps zum Einsparen von Energie ohne Komforteinbuße

- Wählen Sie den Auto-Timer-Betrieb während der Heizperiode, und stellen Sie das Zeitprogramm entsprechend Ihren normalen Bedürfnissen ein.
- Wählen Sie Economy- oder Ferienbetrieb für lange Abwesenheiten und den Sommer.

Möchten Sie Ferienbetrieb eingeben?

<p>set ok + - mode</p> <p>!</p>	<p>Im Ferienbetrieb können Sie den Thermostat so einstellen, dass er während Ihrer Abwesenheit einen konstanten Temperatursollwert einhält.</p> <ul style="list-style-type: none">• Set drücken und  wählen.• ok zur Bestätigung drücken.• Drücken Sie + oder -, um den Temperatursollwert anzupassen.• ok zur Bestätigung drücken.• Drücken Sie + oder -, um die Anzahl Ferientage anzupassen (Hinweis: 0 = Ferienbetrieb Aus).• Mit ok speichern Sie den Wert.• Ist Ferienbetrieb aktiv, werden die verbleibenden Tage angezeigt. <p>Hinweis: Wenn Sie mode während des Ferienbetriebs drücken, wird die Funktion deaktiviert und das Symbol  verschwindet.</p> <p>Sind die Komfort- und Economy-Sollwerte gesperrt, so ist der tiefste Sollwert der Ferienbetriebs-Sollwert. Sie können die Sollwerttemperatur von 5 °C aufwärts bis zum tiefsten, gesperrten Sollwert anpassen.</p>
---	---

Möchten Sie Ihr eigenes Zeitprogramm eingeben?

Option 1: Zeitprogramm mit individueller Tageswahl (P11=0)

set
ok
+
-
mode

Sie können Komfort- oder Economy-Betrieb für jedes 15-minütige Intervall des Tages wählen. Der Zeitbalken von 0:00 bis 24:00 Uhr ermöglicht die Einstellung der Betriebsart über den gewählten Tag.

Beispiel:

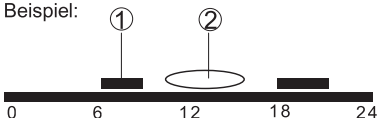

① Sichtbare Segmente: Regelung auf Komfort.

② Unsichtbare Segmente: Regelung auf Economy.

Sind die Einstellungen gespeichert, findet die Umschaltung zwischen den Betriebsarten automatisch statt, sofern Auto-Timer-Betrieb freigegeben ist.

Gehen Sie dabei wie folgt vor:

- 1) **Set** drücken und  wählen.
- 2) **ok** zur Bestätigung drücken.
- 3) Das Zeitprogramm für den Tag Mo (1) wird angezeigt.
- 4) Drücken Sie **+ oder -** zur Tageswahl von Mo(1) bis So (7).
- 5) Drücken Sie **ok**, um das gewählte Datum für den Start der Zeitprogrammierung zu bestätigen.

Während der Programmierung:

- 6) Drücken Sie **mode** für die Betriebsartenauswahl; (Komfort oder Economy) **oder**
- 7) Drücken Sie **+ oder -** zur Anpassung des Zeitsollwerts um 15 Min. für den gewählten Betrieb.
- 8) Drücken Sie **ok**, um das Programm zu speichern.
- 9) Wiederholen Sie die Schritte 4-8 für alle weiteren Tage (nach Bedarf) oder
- 10) Drücken Sie **mode**, um die Zeiteinstellung zu verlassen oder warten Sie kurz, bis das Programm wieder die normale Anzeige zeigt.

Option 2: Zeitprogramm mit 7-Tage Wahl (P11=1)

DE

set
ok
+
-
mode

Sie können die Programmierung für alle 7 Tage gleichzeitig eingeben.

Beispiel:

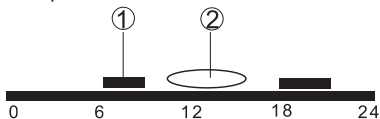

① Sichtbare Segmente: Regelung auf Komfort.

② Unsichtbare Segmente: Regelung auf Economy.

Gehen Sie dabei wie folgt vor:

- 1) Stellen Sie Parameter (P11=1) ein. Siehe "**Möchten Sie Parameter ändern**".
- 2) **Set** drücken und  wählen.
- 3) **ok** zur Bestätigung drücken.
- 4) Das Zeitprogramm für die Periode Mo (1) – So (7) wird angezeigt.
- 5) Drücken Sie **ok** zum Start der Zeitprogrammierung.

Während der Programmierung:

- 6) Drücken Sie **mode** für die Betriebsartenauswahl; (Komfort oder Economy) **oder**
- 7) Drücken Sie **+ oder -** zur Anpassung des Zeitsollwerts um 15 Min. für den gewählten Betrieb.
- 8) Drücken Sie **ok**, um das Programm zu speichern.
- 9) Drücken Sie **mode**, um die Zeiteinstellung zu verlassen oder warten Sie kurz, bis das Programm wieder die normale Anzeige zeigt.

Option 3: Zeitprogramm mit Tageswahl 5-2 (P11=2)

DE

set
ok
+
-
mode

Sie können eine Programmierung für Montag - Freitag sowie Samstag – Sonntag eingeben.

Beispiel:

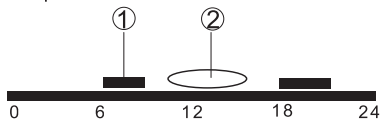

① Sichtbare Segmente: Regelung auf Komfort.

② Unsichtbare Segmente: Regelung auf Economy.

Gehen Sie dabei wie folgt vor:

- 1) Stellen Sie Parameter (P11=2) ein. Siehe "**Möchten Sie Parameter ändern**".
- 2) **Set** drücken und  wählen.
- 3) **ok** zur Bestätigung drücken.
- 4) Das Zeitprogramm für die Periode Mo (1) – Fr (5) wird angezeigt.
- 5) Drücken Sie **+** oder **-** zur Wahl der Periode, Mo(1) - Fr (5) oder Sa (6) - So (7).
- 6) Drücken Sie **ok**, um die gewählte Periode für den Start der Zeitprogrammierung zu bestätigen.

Während der Programmierung:

- 7) Drücken Sie **mode** für die Betriebsartenauswahl; (Komfort oder Economy) oder
- 8) Drücken Sie **+** oder **-** zur Anpassung des Zeitsollwerts um 15 Min. für den gewählten Betrieb.
- 9) Drücken Sie **ok**, um das Programm zu speichern.
- 10) Wiederholen Sie Schritte 5-9 für eine weitere Periode nach Bedarf oder
- 11) Drücken Sie **mode**, um die Zeiteinstellung zu verlassen oder warten Sie kurz, bis das Programm wieder die normale Anzeige zeigt.

Werkseinstellung für das 7-Tage Zeitprogramm

Werks-einst.	Tag/e	Komfortbetrieb	Economy-Betrieb
	Mo (1) – Fr (5)	6:00 – 8:00 hr 17:00 – 22:00 hr	22:00 – 6:00 hr 8:00 – 17:00 hr
Sa (6) – So (7)	7:00 – 22:00 hr	22:00 – 7:00 hr	

DE

Erscheint das Symbol auf der Anzeige? (Nur bei Batterieversion)

Das Symbol  wird angezeigt, wenn die Batterien nahezu leer sind. Ersetzen Sie die Batterien durch 2 neue Alkali-Batterien des Typs AAA. Gehen Sie dabei wie folgt vor:

- Legen Sie 2 neue Alkali-Batterien Typ AAA bereit.
- Entfernen Sie die Batteriehalterung, dann die Batterien. Legen Sie die neuen Batterien ein. Setzen Sie innert 1,5 Minuten den Batteriehalter wieder ein.
- Entsorgen Sie die leeren Batterien ordnungsgemäss entsprechend den gültigen Umweltvorschriften

Möchten Sie die Parameter ändern?

+ - ok mode	<p>Gehen Sie wie folgt vor, um die Regelparameter zu ändern:</p> <ul style="list-style-type: none">• Drücken Sie die Tasten + und - gleichzeitig während 5 Sekunden.• Geben Sie die Tasten frei; "P01" wird unten angezeigt.• Taste + oder - drücken, um zu dem Parameter zu scrollen, der geändert werden muss.• Drücken Sie ok, um den Wert zu ändern und zum Bestätigen.• Wählen und ändern Sie weitere Parameter.• Drücken Sie mode um die Parameter ohne Speichern zu verlassen oder warten Sie kurz, bis das Programm wieder die normale Anzeige zeigt.
--	--

Parameterliste

Parameter Nr.	Beschreibung	Einstellbereich (Werkseinstellung)
P01	Zeitformat	1 = 24:00 Std. (Werk) 2 = 12:00 AM/PM
P02	Wahl von °C oder °F	1 = °C (Werkseinstellung) 2 = °F
P03	Standard-Temperaturanzeige	1 = Raumtemperatur (Werkseinstellung) 2 = Sollwert
P04	Temperaturfühlerabgleich	-3...3 °C Schritte von 0,5 °C (-6...6 K, Schritte von 1 °F) Werkseinstellung: 0 °C
P06	Komfort-Sollwert Sperre	0 = Aus (Werkseinst.) 1 = Ein → gesperrt gem. Einstellung in permanentem Temperatursollwert
P08	Economy-Sollwert Sperre	0 = Aus (Werkseinst.) 1 = EIN → gesperrt gem. Einstellung in perm. Temperatursollwert
P09	Summer	0 = Aus 1 = Ein (Werkseinstellung)
P10	Frostschutz-Symbol anzeigen	0 = Aus (Werkseinst.) 1 = Ein
P11	Zeitprogrammtyp für Auto-Timer	0 = Einzelne Tage (Werkseinstellung) 1 = Alle 7 Tage 2 = 5/2 Tage
P12	Periodic pump run	0 = Aus (Werkseinst.) 1 = Ein

P14	X1 Externer Eingang (nur RDE100.1)	0 = Kein Eingang 1 = Externer Fühler 2 = Digitaler Eingang	←
P15	Temperaturbegrenzung (nur RDE100.1)	0 = Aus (Werkseinst.) 1 = Ein	←
P16	Max Temp. Begrenzung für Bodenheizung (nur RDE100.1)	25...60 °C, Schritt 1 °C oder 77...140 °F, Schritt 1 °F Werkseinst.: 30 °C	←
P17	Fensterkontaktfunktionen (nur RDE 100.1)	0 = NO-Kontakt (Werkseinstellung) 1 = NC-Kontakt	←
P21	Tasten-Abtastrate (Touch-Keys) (nur RDE100.1) Hinweis: Kürzer bedeutet kürzere Batterielebensdauer	0.2 = 0.25 s 0.5 = 0.5 s 1.0 = 1.0 s (Werkseinst.) 1.5 = 1.5 s	
P22	Wiederherstellen der Werkseinstellungen	0 = Aus (Werkseinstellung) 1 = Wiederherstellen	
P23	Informationen zur Software-Version	Keine Einstellungen möglich	
P78	Regelverhalten	0 = Ein/Aus, 1.0K 1 = Ein/Aus, 0.3K 2 = TPI schnell 3 = TPI mittel 4 = TPI langsam (Werkseinst.)	
P89	Vorwärtsschiebung bei max	0, 0.5,...24 h Werkseinstellung: 0 h	
P90	Frühzeitiges Abschalten max	0, 0.5,...6 h Werkseinstellung: 0 h	

DE

Entsorgung Elektronik-Altgerät mit Batterie

DE



Das Gerät gilt für die Entsorgung als Elektronik-Altgerät im Sinne der Europäischen Richtlinie 2012/19/EU und darf nicht als Haushaltsmüll entsorgt werden.

- Entsorgen Sie das Gerät über die dazu vorgesehenen Kanäle.
- Beachten Sie die örtliche und aktuell gültige Gesetzgebung.
- Entsorgen Sie verbrauchte Batterien in den dafür vorgesehenen Sammelstellen.

fr Mode d'emploi

RDE100.. - le thermostat d'ambiance qui vous permet de régler la température que vous voulez à tout moment. Il existe différents types de réglages, que vous pouvez utiliser selon vos besoins.





1. Affichage

 Indique que les piles doivent être remplacées (seulement avec les appareils fonctionnant sur pile)

 Protection antigel active (chauffage)

 Mode Automatique
Afficher et paramétrer le programme horaire du mode Automatique

 Mode Confort

 Mode Économie

 Retour au régime normal
mode

 Entrée externe activée

 Réglage d'une consigne permanente

 Réglage date et heure

 Mode vacances

 Affichage de l'heure

am
pm
Matin : format 12 heures
Après-midi : format 12 heures

 Confirmation
ALL

°F
Température ambiante en degrés Fahrenheit

°C
Température ambiante en degrés Celsius

 Verrouillage des touches activé
Affichage de la température ambiante, consigne, etc.

245

 En demande de chauffage

 Jours de la semaine:
1 = lundi
7 = dimanche

 Barre de temps

 Température ambiante actuelle

2. Touche « mode »

3. Touche « set » (régler)

4. Touche « ok »

5. Touche « - »

6. Touche « + »

7. Porte-piles

Régler la date et l'heure :

set ok + - mode	Procédez comme suit : <ul style="list-style-type: none"> • Appuyez sur set et sélectionnez 🕒 • Appuyez sur ok, pour faire clignoter l'heure • Appuyez sur + ou - pour régler l'heure • Appuyez sur ok pour confirmer • Le jour de la semaine clignote, appuyez sur + ou - pour sélectionner le jour souhaité. • Appuyez sur ok pour enregistrer la valeur • Appuyez sur mode ou attendez quelques instants pour quitter automatiquement le menu
--	---

Verrouiller les touches :





mode	Maintenez la touche mode enfoncée pendant au moins 7 secondes pour activer le verrouillage des touches. Répétez l'opération pour déverrouiller. L'appareil fonctionne normalement lorsque les touches sont verrouillées ; il est cependant impossible d'y apporter des modifications tant que les touches n'ont pas été déverrouillées.
-------------	---

Si la température de la pièce est trop basse ou trop élevée :

+ - ok set mode	En appuyant sur ces touches, vous pouvez temporairement augmenter ou diminuer la consigne de température par pas de 0,5°C/1°F. Procédez comme suit : <ul style="list-style-type: none"> • Appuyez sur + ou - pour changer temporairement la valeur de la consigne. Ce réglage est annulé dès que vous changez de mode de fonctionnement. • La nouvelle valeur est sauvegardée automatiquement après quelques instants, ou appuyez sur ok, set ou mode pour sauvegarder immédiatement. • Utilisez les paramètres P06 et P08 pour verrouiller la modification temporaire des consignes.
--	---

Modifier le mode de fonctionnement :

FR

mode	<p>Le thermostat possède un mode Confort, un mode Économie, un mode Automatique. Vous pouvez passer d'un mode de fonctionnement à l'autre en appuyant sur la touche mode.</p> <p> Mode Confort : sélectionnez ce mode si vous souhaitez maintenir en permanence la température de confort sans utiliser de programme horaire. Il est utilisé par exemple pendant les heures de présence.</p> <p> Mode Économie : sélectionnez ce mode si vous souhaitez maintenir en permanence la température économique sans utiliser de programme horaire. Il est utilisé lorsque vous vous absentez ou la nuit par exemple.</p> <p> Mode Automatique : il permet d'alterner automatiquement entre les 2 modes de fonctionnement Confort et Économie selon les réglages du programme horaire.</p> <p>! Remarque: La protection antigel est activée en permanence. Dès que la température ambiante descend en dessous de 5°C, le chauffage est automatiquement activé .</p>
-------------	--



Modifier les consignes permanentes des différents modes :

set ok + - mode !	<ul style="list-style-type: none">• Appuyez sur set et sélectionnez • Appuyez sur ok pour confirmer• Appuyez sur mode pour choisir le mode Confort ou le mode Économie• Appuyez sur + ou - pour régler la consigne.• Appuyez sur ok pour confirmer• Appuyez sur mode ou attendez quelques instants pour quitter automatiquement le menu <p>Remarque : Ces consignes permanentes sont celles utilisées par le mode Automatique.</p>
--	--

Astuce pour économiser de l'énergie sans compromettre le confort

- Sélectionnez le mode Automatique pendant la saison de chauffage et réglez le programme horaire selon vos habitudes.
- Sélectionnez le mode Économie ou le mode Vacances pendant les périodes d'inoccupation prolongée et durant l'été.

Régler le mode Vacances :

<p>set ok + - mode</p>	<p>Le mode Vacances vous permet de régler le thermostat sur une consigne de température pendant la période où vous serez absent.</p> <ul style="list-style-type: none">• Appuyez sur set et sélectionnez • Appuyez sur ok pour confirmer• Appuyez sur + ou - pour régler la consigne• Appuyez sur ok pour confirmer• Appuyez ensuite sur + ou - pour sélectionner le nombre de jours d'absence. (Remarque: si nombre de jours = 0 alors le mode Vacances est désactivé)• Appuyez sur ok pour enregistrer la valeur• Lorsque le mode Vacances est activé, le nombre de jours restants est affiché à l'écran. <p>! Remarque : Si vous appuyez sur la touche mode alors que le mode Vacances est actif, le mode est désactivé et le symbole  disparaît.</p> <p>Si les consignes des modes Confort et Économie sont verrouillées toutes les deux, c'est la plus basse des deux qui définit la consigne maximum du mode Vacances. Le réglage minimum de cette consigne est de 5°C et ne peut excéder la valeur de la consigne la plus basse verrouillée.</p>
---	--

Personnaliser le programme horaire :

Option 1 : Programme horaire avec sélection individuelle des jours (P11=0)

set
ok
+
-
mode

Les modes Confort et Économie sont réglables sur des plages horaires par intervalles de 15 minutes. La barre de temps vous permet de visualiser les périodes de votre programme sur toute la journée, de 0:00 à 24:00.

Exemple :

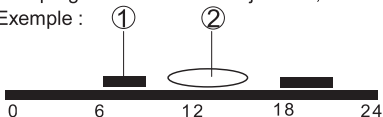

① Segments visibles : Périodes de Confort

② Segments invisibles : Périodes d'Économie

Une fois les réglages enregistrés, le programme débute automatiquement lorsque le mode Automatique est activé.

La programmation s'effectue de la manière suivante :

- 1) Appuyez sur **set** et sélectionnez  AUTO.
- 2) Appuyez sur **ok** pour confirmer.
- 3) Le programme pour la journée du Lun (1) s'affiche.
- 4) Appuyez sur **+** ou **-** pour choisir le jour à programmer, du Lun (1) au Di (7).
- 5) Appuyez sur **ok** pour confirmer le jour souhaité et commencer à définir le programme.

Configuration du programme:

- 6) Appuyez sur **mode** pour choisir un mode de fonctionnement (Confort ou Économie) **ou**
- 7) Appuyez sur **+** ou **-** pour régler la période souhaitée (par intervalles de 15 minutes) pour le mode sélectionné en 6).
- 8) Appuyez sur **ok** pour enregistrer le programme.
- 9) Répétez les étapes 4 à 8 pour les autres jours (si nécessaire) ; sinon
- 10) Appuyez sur **mode** ou attendez quelques instants pour quitter automatiquement le menu.

Option 2: Programme horaire identique pour les 7 jours de la semaine (P11=1)

set
ok
+
-
mode

Vous pouvez définir un programme identique pour les 7 jours de la semaine.

Exemple :

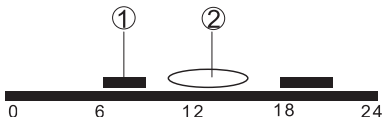

① Segments visibles : Périodes de Confort

② Segments invisibles : Période d'Économie

La programmation s'effectue de la manière suivante :

- 1) Réglez le paramètre P11 sur 1. Pour cela, reportez-vous à la partie "**Modifier des paramètres**".
- 2) Appuyez sur **set** et sélectionnez  AUTO.
- 3) Appuyez sur **ok** pour confirmer.
- 4) Le programme horaire du Lun (1) au Di (7) s'affiche.
- 5) Appuyez sur **ok** pour commencer à programmer.

Configuration du programme :

- 6) Appuyez sur **mode** pour choisir un mode de fonctionnement (Confort ou Économie) **ou**
- 7) Appuyez sur **+** ou **-** pour régler la période souhaitée (par intervalles de 15 minutes) pour le mode sélectionné en 6).
- 8) Appuyez sur **ok** pour enregistrer le programme.
- 9) Appuyez sur **mode** ou attendez quelques instants pour sortir du menu.

Option 3: Programme horaire avec sélection "semaine" (5 jours) et "week-end" (2 jours) (P11=2)

FR

set
ok
+
-
mode

Vous pouvez définir un programme horaire en une seule fois qui s'appliquera du lundi au vendredi, et un autre du samedi au dimanche. Exemple :

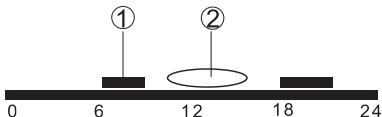

① Segments visibles : Périodes de Confort

② Segments invisibles : Périodes d'Économie

La programmation s'effectue de la manière suivante :

- 1) Réglez le paramètre P11 sur 2. Reportez-vous à la partie "**Modifier des paramètres**".
- 2) Appuyez sur **set** et sélectionnez  AUTO.
- 3) Appuyez sur **ok** pour confirmer.
- 4) Le programme horaire du Lun (1) au Ven (5) s'affiche.
- 5) Appuyez sur **+** ou **-** pour choisir le bloc jours souhaité (Lun (1) à Ven (5) ou Sa (6) et Di (7)).
- 6) Appuyez sur **ok** pour confirmer le bloc jours souhaité.

Configuration du programme :

- 7) Appuyez sur **mode** pour choisir un mode de fonctionnement (Confort ou Économie) **ou**
- 8) Appuyez sur **+** ou **-** pour régler la période souhaitée (par intervalles de 15 minutes) pour le mode sélectionné en 7).
- 9) Appuyez sur **ok** pour enregistrer le programme.
- 10) Répétez les étapes 5 à 9 pour l'autre bloc jours si nécessaire ; sinon
- 11) Appuyez sur **mode** ou attendez quelques instants pour sortir du menu.

Réglages usine du programme hebdomadaire

Valeur par défaut	Jour/s	Mode Confort	Mode Économie
	Lun (1) – Ven (5)	6:00 – 8:00 17:00 – 22:00	22:00 – 6:00 8:00 – 17:00
	Sa (6) – Di (7)	7:00 – 22:00	22:00 – 7:00

FR

Apparition du symbole (seulement sur les modèles fonctionnant sur piles)

Le symbole  s'affiche lorsque les piles sont faibles. Remplacez-les par 2 nouvelles piles alcalines de type AAA. Procédez comme suit :

- Retirez le porte-piles, puis les piles,
- Insérez les nouvelles piles et remettez le porte-piles en place dans un délai de 1,5 minutes.
- Assurez-vous que les piles usagées sont éliminées correctement, conformément aux prescriptions environnementales.

Modifier des paramètres :

+ – ok mode	<ul style="list-style-type: none">• Appuyez sur + et – simultanément pendant 5 secondes. Le paramètre "P 1" s'affiche au bas de l'écran• Relâchez les touches.• Appuyez sur + et – pour afficher le paramètre souhaité.• Appuyez sur ok pour le sélectionner puis• Appuyez sur + et – pour régler sa valeur• Appuyez sur ok pour confirmer la nouvelle valeur• Appuyez sur mode à tout moment pour quitter le réglage des paramètres. Vous pouvez aussi attendre quelques instants pour être automatiquement redirigé vers l'écran habituel.
--------------------------------	---

Liste des paramètres

FR

N° de paramètre	Description	Plage de réglage (par défaut)
P 1	Format heure	1 = 24 heures (par défaut) 2 = 12:00 AM/PM
P 2	Affichage de la température en °C ou en °F	1 = °C (par défaut) 2 = °F
P 3	Affichage standard de la température	1 = Température ambiante (par défaut) 2 = Consigne
P 4	Calibrage de la sonde température	-3...3 °C Par pas de 0,5°C (-6...6 °F, par pas de 1 °F) par défaut : 0 °C
P 6	Verrouillage de la consigne Confort	0 = Désactivé (par défaut) 1 = Marche → verrouillé sur la consigne de température paramétrée
P 8	Verrouillage de la consigne Economie	0 = Désactivé (par défaut) 1 = Marche → verrouillé sur la consigne de température paramétrée
P 9	Avertisseur sonore	0 = Désactivé 1 = Activé (par défaut)
P10	Affichage du symbole de la protection antigel	0 = Désactivé (par défaut) 1 = Activé
P11	Type de programme horaire pour mode Automatique	0 = Programme établi individuellement pour chaque jour (par défaut) 1 = Programme identique pour les 7 jours de la semaine 2 = Programme "semaine" (5 jours) et "week-end" (2 jours)
P12	Relance périodique de la pompe	0 = OFF (par défaut) 1 = Marche

P14	Entrée externe X1 (seulement pour RDE100.1)	0 = pas d'entrée 1 = sonde externe 2 = entrée logique
P15	Limitation de la température (seulement pour RDE 100.1)	0 = Désactivé (par défaut) 1 = Marche
P16	Température maximale pour chauffage au sol (seulement pour RDE 100.1)	25...60 °C, par pas de 1 °C ou 77...140 °F, par pas 1 °F par défaut: 30 °C
P17	Fonctionnalités contact fenêtre (seulement pour RDE 100.1)	0 = Contact normalement ouvert (par défaut) 1 = Contact normalement fermé
P21	Fréquence de lecture des touches (seulement pour RDE100.1) Remarque: une fréquence de lecture élevée réduit la durée de vie de la pile	0,2 = 0,25 s 0,5 = 0,5 s 1.0 = 1.0 s (par défaut) 1,5 = 1,5 s
P22	Restaurer les réglages usine	0 = Désactivé (par défaut) 1 = Restaurer
P23	Informations sur la version du logiciel	Non modifiable
P78	Comportement de commande	0 = On/Off, 1.0 K 1 = On/Off, 0.3 K 2 = TPI rapide 3 = TPI moyen 4 = TPI lent (par défaut)
P89	Décalage avant sur max	0, 0.5,...24 h par défaut : 0 h
P90	Max arrêt précoce	0, 0.5,...6 h par défaut : 0 h

FR

Élimination d'un appareil électronique usagé avec une batterie

FR



L'appareil est considéré comme un appareil électronique usagé destiné à être éliminé au sens de la Directive européenne 2012/19/UE et il ne doit pas être jeté comme un déchet ménager.









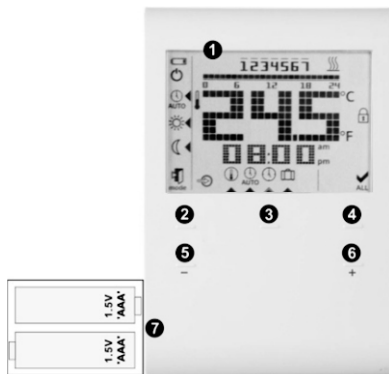
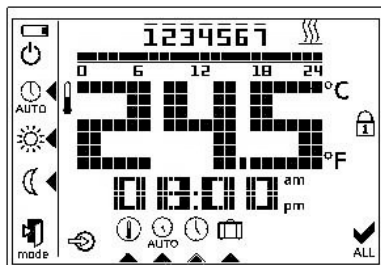







- Jetez l'appareil par les voies prévues à cet effet.
- Veuillez respecter la législation locale actuellement en vigueur.
- Jetez les batteries usagées dans les centres de collecte prévus à cet effet.

it Istruzioni operative

RDE100.. – Il cronotermostato consente di mantenere la temperatura desiderata nei periodi impostati. E' possibile mantenere le impostazioni di fabbrica (vedi tabella sotto) o adattare le regolazioni alle proprie esigenze.

IT



1. Display			
	Indica che la batteria deve essere sostituita (solamente con versione alimentata a batteria)		Digits per ora corrente
	E' attiva la protezione antigelo	am pm	Mattino: modalità 12 ore Pomeriggio: modalità 12 ore
 AUTO	Impostazione modalità automatica	 ALL	Conferma
	Visualizza e configura il programma orario	°F	Temperatura ambiente in gradi Fahrenheit
	Impostazione modalità comfort	°C	Temperatura ambiente in gradi Celsius
	Impostazione modalità economia		Blocco tasti attivato
 mode	Uscita	245	Display temperatura ambiente, setpoint, etc.
	Ingresso esterno attivato		Riscaldamento ON
	Impostazione setpoint permanente	1 2 3 4 5 6 7	Giorni della settimana 1 = Lunedì, 7 = Domenica
	Impostazione giorno e ora		Barra oraria
	Impostazione modalità vacanza		Temperatura ambiente attuale
2. Cambio modalità operativa (mode)			
3. Impostazione (set)			
4. OK			
5. Valore in diminuzione			
6. Valore in aumento			
7. Vano batterie			

Valori di fabbrica		
Giorno/i	Modalità comfort (setpoint 20°C)	Modalità economia (setpoint 16°C)
Lun (1) .. Ven (5)	6:00 .. 8:00 h - 17:00 .. 22:00 h	22:00 .. 6:00 h - 8:00 .. 17:00 h
Sab (6) – Dom (7)	7:00 .. 22:00 h	22:00 .. 7:00 h

Qualora le impostazioni di fabbrica sopra riportate non risultino adatte alle proprie esigenze è possibile procedere con l'impostazione manuale dei programmi orari e dei setpoint.

Impostazione data e ora.

Procedere come segue:

- Premere **set** più volte fino a selezionare l'icona orologio 
- Premere **ok** e l'ora lampeggia per l'impostazione
- Premere **+** o **–** per cambiare l'ora
- Premere **ok** per confermare l'ora
- I giorni della settimana lampeggiano, premere **+** o **–** per selezionare il giorno desiderato
(Lun=1 Mar=2 Mer=3 Gio=4 Ven=5 Sab=6 Dom=7)
- Premere **ok** per salvare il giorno
- Premere **mode** per uscire o attendere 10s per uscire automaticamente dalla programmazione

→Nota: se durante la programmazione non si preme nessun tasto per più di 10s il display ritorna al punto precedente.

Impostazione del programma orario

Il cronotermostato consente di impostare il programma orario in tre modi diversi:

IT Opzione 1 → Programma orario con selezione individuale dei giorni (programma orario differente per ogni giorno della settimana)

Opzione 2 → Programma orario unico per tutti i giorni della settimana

Opzione 3 → Programma orario con selezione 5-2 (programma orario unico per i giorni feriali lun-ven e programma orario unico per il weekend).

Opzione 1: Programma orario con selezione individuale dei giorni (parametro P11=0 impostazione di fabbrica).

E' possibile selezionare i periodi di comfort e di economia con intervalli minimi di 15 minuti. La barra di commutazione oraria 0:00 – 24:00 permette di visualizzare i periodi di comfort e di economia impostati di tutta la giornata dove ogni quadretto rappresenta 1 ora.

Esempio:

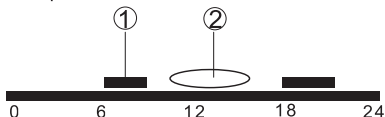

① Segmenti visibili: Periodi di comfort

② Segmenti invisibili: Periodi di economia

In modalità automatica  , una volta che le impostazioni sono salvate, la commutazione tra le modalità operative di comfort ed economia avviene automaticamente.

Procedere come segue:

- 1) Premere **set** più volte fino a selezionare l'icona .
- 2) Premere **ok** per conferma.
- 3) E' mostrato il programma orario per il giorno Lun (1).

- 4) Premere **+** o **-** per selezionare il giorno da programmare, da Lun (1) a Dom (7).
- 5) Premere **ok** per confermare la data selezionata e iniziare la programmazione oraria.

Durante la programmazione:

- 6) Premere **mode** per selezionare Comfort ☀ o Economia ☾
- 7) Premere **+** o **-** per avanzare in avanti o indietro nella barra di programmazione oraria ed impostare la modalità operativa appena selezionata (Comfort o Economia) sull'ora visualizzata con passi di 15 minuti.
- 8) Una volta impostato il programma orario desiderato, premere **ok** per salvarlo.
- 9) Ripetere i passaggi da 4-8 fino a che tutti i giorni sono programmati. Oppure:
- 10) Premere **mode** per uscire o attendere 10s per uscire automaticamente dalla programmazione

Opzione 2: Programma orario unico per tutti i giorni della settimana (P11=1)

E' possibile selezionare i periodi di comfort e di economia con intervalli minimi di 15 minuti. La barra di commutazione oraria 0:00 – 24:00 permette di visualizzare i periodi di comfort e di economia impostati di tutta la giornata dove ogni quadretto rappresenta 1 ora.

Esempio:

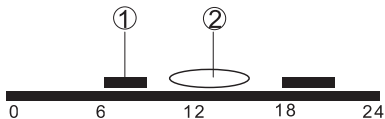

① Segmenti visibili: Periodi di comfort



② Segmenti invisibili: Periodi di economia

In modalità automatica  AUTO, una volta che le impostazioni sono salvate, la commutazione tra le modalità operative di comfort ed economia avviene automaticamente.

Procedere come segue:

- 1) Impostare il parametro (P11=1). Prego fare riferimento alla sezione "Modifica parametri".
- 2) Premere **set** più volte fino a selezionare l'icona  AUTO.
- 3) Premere **ok** per conferma.
- 4) E' mostrato il programma orario valido per tutti i giorni della settimana **1 2 3 4 5 6 7**.
- 5) Premere **ok** per confermare e iniziare la programmazione oraria.

Durante la programmazione:

- 6) Premere **mode** per selezionare Comfort  o Economia 
- 7) Premere **+** o **-** per avanzare in avanti o indietro nella barra di programmazione oraria ed impostare la modalità operativa appena selezionata (Comfort o Economia) sull'ora visualizzata con passi di 15 minuti.
- 8) Una volta impostato il programma orario desiderato, premere **ok** per salvarlo.
- 9) Premere **mode** per uscire o attendere 10s per uscire automaticamente dalla programmazione

Opzione 3: Programma orario con selezione 5-2 (P11=2)

Programma orario con selezione 5-2 (programma orario unico per i giorni feriali lun-ven e programma orario unico per il weekend).

E' possibile selezionare i periodi di comfort e di economia con intervalli minimi di 15 minuti. La barra di commutazione oraria 0:00 – 24:00 permette di visualizzare i periodi di comfort e di economia impostati di tutta la giornata dove ogni quadretto rappresenta 1 ora.

Esempio

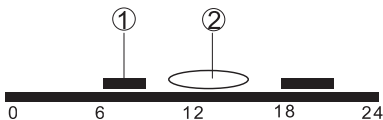

① Segmenti visibili: Periodi di comfort

② Segmenti invisibili: Periodi di economia

Procedere come segue:

1) Impostare il parametro (P11=2). Prego fare riferimento alla sezione "Modifica parametri".

2) Premere **set** più volte fino a selezionare l'icona .

3) Premere **ok** per conferma.

4) E' mostrato il programma orario valido per i giorni feriali 12345

5) Premere **+** o **-** per selezionare il periodo giorni feriali 12345 o weekend 67.

6) Premere **ok** per confermare il periodo selezionato e iniziare la programmazione oraria.

Durante la programmazione:

7) Premere **mode** per selezionare Comfort  o Economia 

8) Premere **+** o **-** per avanzare in avanti o indietro nella barra di programmazione oraria ed impostare la modalità operativa appena selezionata (Comfort o Economia) sull'ora visualizzata con passi di 15 minuti.



- 9) Una volta impostato il programma orario desiderato, premere **ok** per salvarlo.
- 10) Ripetere eventualmente i passaggi da 5-9 per programmare l'altro periodo (giorni feriali **12345** o weekend **67**). Oppure:
- 11) Premere **mode** per uscire o attendere 10s per uscire automaticamente dalla programmazione

Modifica temporanea setpoint di temperatura ambiente

Premere **+** o **-** per aumentare o diminuire il setpoint di temperatura ambiente, con incrementi di 0.5 °C. Procedere come segue:

- Premere **+** o **-** per cambiare temporaneamente il setpoint attivo al momento. Al primo cambio di modalità operativa sarà ripristinato il valore precedente.
- Premere **ok**, **set** o **mode** per salvare il valore o attendere 10s per salvare ed uscire automaticamente dalla programmazione
- Tramite i parametri P06 e P08 è possibile cambiare i setpoint permanentemente. Vedi sezione "Modifica parametri".

Modifica permanente setpoint di temperatura ambiente

- Premere **set** e selezionare 
- Premere **ok** per confermare
- Premere **mode** per selezionare una modalità operativa, Comfort  o Economia 
- Premere **+** o **-** per cambiare permanentemente il setpoint.
- Premere **ok** per confermare
- Premere **mode** per uscire o attendere 10s per uscire automaticamente dalla programmazione

Cambio modalità operativa tra Comfort, Economia, Automatico e Antigelo.

IT

Le modalità operative selezionabili del cronotermostato sono:

Comfort , Economia , Automatico  AUTO e Antigelo .



La commutazione tra le modalità operative avviene manualmente premendo il pulsante **mode**.

 **Modalità Comfort** selezionata permanentemente (24 h) con un setpoint di temperatura ambiente di 20 °C (valore di fabbrica). Selezionare questa modalità di funzionamento se si vuole mantenere la temperatura ambiente permanentemente in comfort senza nessun programma orario. E' usata, ad esempio, durante un lungo periodo di occupazione.

 **Modalità economia** selezionata permanentemente (24 h) con un setpoint di temperatura ambiente di 16 °C (valore di fabbrica).

Selezionare questa modalità di funzionamento se si vuole mantenere la temperatura ambiente permanentemente in economia senza nessun programma orario. E' usata, ad esempio, durante un lungo periodo di non occupazione.

 **Modalità automatica** è una modalità operativa dove i periodi di Comfort ed Economia si alternano secondo il programma orario impostato.

 **Protezione antigelo** è una funzione sempre attiva. Quando la temperatura scende al di sotto dei 5°C, automaticamente si attiva il riscaldamento .

Nota: l'icona della funzione Antigelo può essere visualizzata a display attraverso il parametro P10 (fare riferimento alla sezione "Modifica parametri").

Attivare il blocco dei tasti



Premere e tenere premuto il pulsante **mode** per almeno 7 secondi.

Sul display compare l'icona . Questo attiva il blocco di tutti i tasti. Premere nuovamente il pulsante **mode** per almeno 7 secondi per sbloccare i tasti.

Nota: Il cronotermostato lavora normalmente anche se il blocco dei tasti è attivo, ma non è possibile eseguire nessuna tipologia di comando o impostazione dei dati finché il blocco dei tasti non è disattivato.

Impostare la modalità vacanza

In modalità vacanza è possibile impostare un setpoint di temperatura dedicato, per mantenere costante la temperatura ambiente per tutto il periodo di assenza previsto.

- Premere **set** e selezionare 
- Premere **ok** per conferma
- Premere **+** o **-** per cambiare il setpoint di temperatura dedicato
- Premere **ok** per conferma
- Premere **+** o **-** per impostare il numero dei giorni di vacanza (Nota: 0 = Modalità vacanza OFF)
- Premere **ok** per salvare il valore
- Quando la modalità vacanza è attivata, sul display compare il simbolo  insieme al numero dei giorni rimanenti.

Nota: la pressione del tasto **mode** quando la modalità vacanza è attiva, ne determina la disattivazione (il simbolo  scompare).

Simbolo batteria scarica sul display. (Solo per versioni alimentate a batteria)

Quando sul display appare il simbolo  le batterie sono scariche. Sostituirle con due nuove batterie alcaline del tipo AAA (ministilo). Procedere come segue:

- Acquistare 2 batterie alcaline ministilo tipo AAA
- Rimuovere il vano delle batterie, togliere le batterie scariche ed, entro 1,5 minuti, sostituirle con quelle nuove. Richiudere il vano delle batterie.
- Assicurarsi che le batterie scariche vengano correttamente smaltite secondo le normative vigenti



Consigli per risparmiare energia senza rinunciare al comfort

Mantenere in modo automatico (Auto) durante il periodo di riscaldamento impostando la programmazione oraria in base alle proprie esigenze.

Modifica parametri di controllo.

I parametri di controllo riportati nella tabella sotto consentono di attivare alcune utili funzionalità come ad esempio la calibrazione della sonda di temperatura, il blocco dei setpoint, la limitazione della temperatura ecc.

Per la modifica dei parametri di controllo, procedere come segue:

- Premere **+** e **-** contemporaneamente per almeno 5 secondi
- Dopo averli rilasciati sul display apparirà "P01"
- Premere **+** e **-** per scorrere i parametri che devono essere modificati (vedi lista parametri di controllo)
- Premere **ok** per selezionare il parametro visualizzato
- Premere **+** o **-** per modificare il valore
- Premere **ok** per confermare il valore modificato
- Premere **mode** per uscire dai parametri senza salvarli o attendere per uscire automaticamente dal programma

Lista parametri di controllo

IT

Parametro	Descrizione	Valori di impostazioni (di fabbrica)
P01	Formato ora	1 = 24:00 ore (impostazione di fabbrica) 2 = 12:00 AM/PM
P02	Unità di misura in °C o °F	1 = °C (impostazione di fabbrica) 2 = °F
P03	Temperatura visualizzata a display	1 = Temperatura ambiente (impostazione di fabbrica) 2 = Setpoint
P04	Calibrazione sensore di temperatura	-3...3 °C con passi di 0.5 °C (-6...6 °F, con passi di 1 °F) impostazione di fabbrica: 0 °C
P06	Setpoint di comfort bloccato	0 = OFF (impostazione di fabbrica) 1 = ON → Bloccato, se volete impostare un setpoint di temperatura permanente
P08	Setpoint di economia bloccato	0 = OFF (impostazione di fabbrica) 1 = ON → Bloccato, se volete impostare un setpoint di temperatura permanente
P09	Buzzer (cicalino)	0 = OFF 1 = ON (impostazione di fabbrica)
P10	Mostra l'icona di protezione antigelo	0 = OFF (impostazione di fabbrica) 1 = ON
P11	Tipo di programmazione oraria automatica	0 = selezione individuale dei giorni: programma orario differente per ogni giorno della settimana (impostazione di fabbrica) 1 = Programma orario unico per tutti i giorni della settimana 2 = Programma orario con selezione 5-2 (programma orario unico per i giorni feriali lun-ven e programma orario unico per il weekend)
P12	Avvio periodico pompa di circolazione	0 = OFF (Impostazione di fabbrica) 1 = ON

P14	Ingresso esterno X1 (solo per RDE100.1)	0 = Nessun ingresso 1 = Sensore esterno 2 = Ingresso digitale
P15	Limitazione temperatura (solo per RDE100.1)	0 = OFF (impostazione di fabbrica) 1 = ON
P16	Massima limitazione temperatura per riscaldamento pannelli a pavimento (solo per RDE100.1)	25...60 °C, con passi di 1 °C o 77...140 °F, con passi di 1 °F Impostazione di fabbrica: 30 °C
P17	Contatto finestra futuro (solo per RDE 100.1)	0 = Contatto normalmente aperto (impostazione di fabbrica) 1 = Contatto normalmente chiuso
P21	Tempo di aggiornamento touchpad (Solo per RDE100.1) Nota: un tempo di aggiornamento più breve comporta un maggior consumo delle batterie.	0.2 = 0.25 s 0.5 = 0.5 s 1.0 = 1.0 s (impostazione di fabbrica) 1.5 = 1.5 s
P22	Ripristino impostazioni di fabbrica	0 = OFF (impostazione di fabbrica) 1 = Attivazione ripristino
P23	Versione software	Solo lettura
p78	Comportamento di controllo	0 = Acceso/Spento, 1.0 K 1 = Acceso/Spento, 0.3 K 2 = TPI Veloce 3 = TPI Medio 4 = TPI Lento(impostazione di fabbrica)
P89	Tempo massimo di avvio avanzato	0, 0.5,...24 ore impostazione di fabbrica: 0 ore
P90	Tempo massimo di spegnimento avanzato	0, 0.5,...6 ore impostazione di fabbrica: 0 ore

Smaltimento di rifiuti di apparecchiature elettroniche con batterie

IT



L'apparecchio è considerato, ai fini dello smaltimento, come rifiuto di apparecchiatura elettronica ai sensi della Direttiva Europea 2012/19/UE e non deve essere smaltito insieme ai rifiuti domestici.

- Smaltire l'apparecchio tramite gli appositi canali.
- Rispettare le normative locali attualmente in vigore.
- Smaltire le batterie usate nei punti di raccolta pre-disposti.











eI Οδηγίες λειτουργίας

RDE100.. – Ο θερμοστάτης χώρου που σας επιτρέπει να ρυθμίσετε την ιδανική θερμοκρασία την ώρα που επιθυμείτε.

EL



1. Ενδείξεις

-  Ένδειξη για αντικατάσταση μπαταριών (μόνο για τις εκδόσεις με μπαταρίες)
-  Αντιπαγετική προστασία (θέρμανση) ενεργή
-  Αυτόματη λειτουργία μέσω χρονοδιακόπτη
-  Ένδειξη και ρύθμιση χρονοπρογράμματος
-  Λειτουργία άνεσης
-  Λειτουργία εξοικονόμησης
-  Έξοδος/Απουσία
-  Ενεργοποιημένη εξωτερική είσοδος
-  Μόνιμη ρύθμιση επιθυμητής τιμής
-  Ρύθμιση ημέρας και ώρας
-  Ρύθμιση λειτουργίας διακοπών



Ψηφία ένδειξης ώρας

am

Πρωινή: 12-ωρη ένδειξη

pm

Απογευματινή: 12-ωρη ένδειξη



ALL

Επιβεβαίωση

°F

Θερμοκρασία χώρου σε βαθμούς Fahrenheit

°C

Θερμοκρασία χώρου σε βαθμούς Celsius



Ενεργοποίηση κλειδώματος πληκτρολογίου

245

Ένδειξη θερμοκρασίας χώρου, επιθυμητής, κτλ.



Ενεργοποιημένη θέρμανση

1 2 3 4 5 6 7

Ημέρα 1 = Δευτέρα, 7 = Κυριακή



Μπάρα χρόνου



Τρέχουσα θερμοκρασία χώρου

2. Αλλαγή τρόπου λειτουργίας (mode)

3. Ρύθμιση (set)

4. OK

5. Μείωση τιμής

6. Αύξηση τιμής

7. Θήκη μπαταριών

Θέλετε να διορθώσετε την ώρα και την ημέρα;

set ok + - mode	<p>Ενεργήστε ως εξής:</p> <ul style="list-style-type: none"> • Πιέστε set και επιλέξτε 🕒 • Πιέστε ok και η ώρα αναβοσβήνει για ρύθμιση • Πιέστε + ή - για να διορθώσετε την ώρα • Πιέστε ok για επιβεβαίωση • Η ημέρα αναβοσβήνει, πιέστε + ή - για επιλογή της επιθυμητής ημέρας • Πιέστε ok για αποθήκευση της τιμής • Πιέστε mode για έξοδο ή περιμένετε κάποιο χρονικό διάστημα για επιστροφή στην αρχική οθόνη
--	---

Επιθυμείτε να κλειδώσετε το πληκτρολόγιο;





mode	<p>Κρατήστε το mode πατημένο για τουλάχιστον 7 δευτερόλεπτα. Έτσι ενεργοποιείτε το κλειδωμα των πλήκτρων. Πράξτε το ίδιο για την απενεργοποίηση. Η συσκευή λειτουργεί κανονικά και με κλειδωμένα πλήκτρα αλλά δεν είναι δυνατή η οποιαδήποτε αλλαγή μέχρι να ξεκλειδωθούν και πάλι.</p>
-------------	--

Είναι οι χώροι σας πολύ ζεστοί/κρύοι;

+ - ok set mode	<p>Πιέστε + ή - για να αυξήσετε ή μειώσετε την επιθυμητή θερμοκρασία για το χώρο με βήμα 0.5 °C / 1 °F.</p> <p>Ενεργήστε ως εξής:</p> <ul style="list-style-type: none"> • Πιέστε + ή - για να διορθώσετε την επιθυμητή θερμοκρασία προσωρινά. Η επιθυμητή θερμοκρασία θα επανέλθει στην αρχική της τιμή όταν γίνει αλλαγή του τρόπου λειτουργίας. • Μπορείτε να περιμένετε κάποιο χρονικό διάστημα για αποθήκευση της τιμής ή μπορείτε να πιέσετε ok, set ή mode για άμεση αποθήκευση • Μπορείτε επίσης να κλειδώσετε τις επιθυμητές τιμές μέσω των παραμέτρων P06 και P08.
--	---

Επιθυμείτε να αλλάξετε τον τρόπο λειτουργίας;

EL

mode	<p>Ο θερμοστάτης παρέχει τις λειτουργίες Άνεσης, Εξοικονόμησης, Αυτόματο. Η αλλαγή μεταξύ των καταστάσεων μπορεί να γίνει χειροκίνητα πιέζοντας το mode.</p> <p> Η λειτουργία Άνεσης είναι μία μόνιμη (24 h) επιλογή της επιθυμητής θερμοκρασίας Άνεσης (20 °C). Επιλέξτε αυτή τη λειτουργία όταν επιθυμείτε τη μόνιμη διατήρηση της θερμοκρασίας Άνεσης χωρίς κάποιο χρονοπρόγραμμα. Χρησιμοποιείται για παράδειγμα κατά τη διάρκεια περιόδων παρουσίας.</p> <p> Η λειτουργία Εξοικονόμησης είναι μία μόνιμη (24 h) επιλογή της επιθυμητής θερμοκρασίας Εξοικονόμησης (16 °C). Επιλέξτε αυτή τη λειτουργία όταν επιθυμείτε τη μόνιμη διατήρηση της θερμοκρασίας Εξοικονόμησης χωρίς κάποιο χρονοπρόγραμμα. Χρησιμοποιείται για περιόδους απουσίας, π.χ. τη νύχτα</p> <p> ΑΥΤΟ Στην Αυτόματη λειτουργία ο τρόπος λειτουργίας μεταβάλλεται αυτόματα μεταξύ Άνεσης και Εξοικονόμησης σύμφωνα με το χρονοπρόγραμμα που έχει οριστεί.</p> <p>! Σημείωση: Η ανπιπαγετική προστασία αποτελεί μία λειτουργία που είναι συνεχώς ενεργοποιημένη ανεξάρτητα από τον επιλεγμένο τρόπο λειτουργίας. Αν η θερμοκρασία χώρου πέσει κάτω από 5 °C, η συσκευή αυτόματα ενεργοποιεί τη θέρμανση .</p>
-------------	---

Επιθυμείτε να ρυθμίσετε μόνιμα τις επιθυμητές θερμοκρασίες;

set	• Πιέστε set και επιλέξτε 
ok	• Πιέστε ok για επιβεβαίωση
+	• Πιέστε mode για να επιλέξετε τη λειτουργία της οποίας θα αλλάξετε την επιθυμητή θερμοκρασία, Άνεση ή Εξοικονόμηση
-	
mode	• Πιέστε + ή - για μόνιμη διόρθωση της επιθυμητής θερμοκρασίας. • Πιέστε ok για επιβεβαίωση

!	<ul style="list-style-type: none"> Πιέστε mode για έξοδο ή περιμένετε κάποιο χρονικό διάστημα για αυτόματη έξοδο <p>Σημείωση: Η μόνιμη επιθυμητή θερμοκρασία χρησιμοποιείται κατά τη διάρκεια της Αυτόματης λειτουργίας</p>
----------	--



Προτάσεις για εξοικονόμηση ενέργειας χωρίς να θυσιαστεί η άνεση

- Επιλέξτε την Αυτόματη λειτουργία κατά την περίοδο θέρμανσης και ρυθμίστε το χρονοπρόγραμμα σύμφωνα με τις απαιτήσεις σας
- Επιλέξτε τη λειτουργία Εξοικονόμησης ή Διακοπών για μεγάλες περιόδους απουσίας και κατά τη διάρκεια της καλοκαιρινής περιόδου

Επιθυμείτε να ρυθμίσετε τη λειτουργία Διακοπών;

set ok + - mode	<p>Στη λειτουργία Διακοπών, μπορείτε να ρυθμίσετε το θερμοστάτη σε μία σταθερή επιθυμητή θερμοκρασία κατά τη διάρκεια των ημερών απουσίας.</p> <ul style="list-style-type: none"> Πιέστε set και επιλέξτε Πιέστε ok για επιβεβαίωση Πιέστε + ή - για διόρθωση της επιθυμητής θερμοκρασίας Πιέστε ok για επιβεβαίωση Μετά πιέστε + ή - για να ορίσετε τον αριθμό των ημερών που θα λείψετε για διακοπές (Σημείωση: 0 = Λειτουργία Διακοπών απενεργοποιημένη) Πιέστε ok για αποθήκευση τιμής Όταν η λειτουργία Διακοπών είναι ενεργοποιημένη, στην οθόνη εμφανίζεται ο αριθμός των ημερών που απομένουν <p>! Σημείωση: Αν πιέσετε το πλήκτρο mode κατά τη διάρκεια της λειτουργίας Διακοπών, η λειτουργία απενεργοποιείται και το σύμβολο εξαφανίζεται.</p> <p>Αν και οι δύο επιθυμητές τιμές θερμοκρασιών Άνεσης και Εξοικονόμησης είναι κλειδωμένες, η χαμηλότερη επιθυμητή τιμή θα είναι και επιθυμητή τιμή για τη θερμοκρασία λειτουργίας Διακοπών. Μπορείτε να ορίσετε την επιθυμητή τιμή της θερμοκρασίας από 5 °C μέχρι τη χαμηλότερη κλειδωμένη επιθυμητή τιμή.</p>
--	---

Επιθυμείτε να ορίσετε το δικό σας χρονοπρόγραμμα; Επιλογή 1: Ανεξάρτητο χρονοπρόγραμμα για κάθε ημέρα (P11=0)

EL

set
ok
+
-
mode

Μπορείτε να επιλέξετε λειτουργία Άνεσης ή εξοικονόμησης για κάθε διάστημα 15 λεπτών της ημέρας.. Η μπάρα χρόνου από 0:00 έως 24:00 σας επιτρέπει να ορίσετε τον τρόπο λειτουργίας για κάθε επιλεγμένη(ες) ημέρα(ες).
Παράδειγμα:

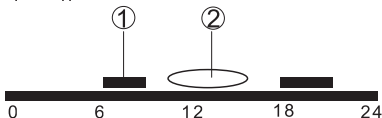

- ① Ορατοί τομείς: έλεγχος σε θερμοκρασία Άνεσης
- ② Αόρατοι τομείς: έλεγχος σε θερμοκρασία εξοικονόμησης

Όταν οι ρυθμίσεις αποθηκευτούν, η αλλαγή του τρόπου λειτουργίας γίνεται αυτόματα όταν ενεργοποιηθεί η Αυτόματη λειτουργία.

Ενεργήστε ως εξής:

- 1) Πιέστε **set** και επιλέξτε  **AUTO**.
- 2) Πιέστε **ok** για επιβεβαίωση.
- 3) Το χρονοπρόγραμμα της ημέρας Δευτ(1) εμφανίζεται.
- 4) Πιέστε **+** ή **-** για να επιλέξετε ημέρα, από Δευτ(1) έως Κυρ(7).
- 5) Πιέστε **ok** για επιβεβαιώσετε την επιλεγμένη ημέρα και να προγραμματίσετε τις ώρες λειτουργίας.

Κατά τη διάρκεια των βημάτων προγραμματισμού:

- 6) Πιέστε **mode** για να επιλέξετε τρόπο λειτουργίας, (Άνεσης ή Εξοικονόμησης) ή
- 7) Πιέστε **+** ή **-** για να θέσετε το χρόνο διάρκειας (ανά 15 λεπτά) του επιλεγμένου τρόπου λειτουργίας.
- 8) Πιέστε **ok** για να αποθηκεύσετε το χρονοπρόγραμμα.
- 9) Επαναλάβετε τα βήματα 4-8 και για τις υπόλοιπες ημέρες (αν απαιτείται) διαφορετικά
- 10) Πιέστε **mode** ή περιμένετε κάποιο χρονικό διάστημα για αυτόματη έξοδο.

Επιλογή 2: Κοινό χρονοπρόγραμμα για όλες τις ημέρες (P11=1)

set
ok
+
-
mode

Μπορείτε να ορίσετε το ίδιο χρονοπρόγραμμα και για τις 7 ημέρες της εβδομάδας.

Παράδειγμα:

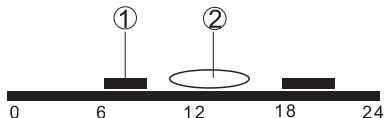

- ① Ορατοί τομείς: έλεγχος σε θερμοκρασία Άνεσης
- ② Αόρατοι τομείς: έλεγχος σε θερμοκρασία εξοικονόμησης

Ενεργήστε ως εξής:

- 1) Ρυθμίστε την παράμετρο (P11=1). Βλέπε τμήμα " **Επιθυμείτε να αλλάξετε τις παραμέτρους**".
- 2) Πιέστε **set** και επιλέξτε  AUTO.
- 3) Πιέστε **ok** για επιβεβαίωση.
- 4) Εμφανίζεται το χρονοπρόγραμμα για Δευτ (1) – Κυρ (7).
- 5) Πιέστε **ok** για να προγραμματίσετε τις ώρες λειτουργίας.

Κατά τη διάρκεια των βημάτων προγραμματισμού:

- 6) Πιέστε **mode** για να επιλέξετε τρόπο λειτουργίας, (Άνεσης ή Εξοικονόμησης) ή
- 7) Πιέστε **+** ή **-** για να θέσετε το χρόνο διάρκειας (ανά 15 λεπτά) του επιλεγμένου τρόπου λειτουργίας.
- 8) Πιέστε **ok** για να αποθηκεύσετε το χρονοπρόγραμμα.
- 9) Πιέστε **mode** ή περιμένετε κάποιο χρονικό διάστημα για αυτόματη έξοδο.

EL

Επιλογή 3: Χρονοπρόγραμμα με επιλογή 5-2 ημερών (P11=2)

EL

set
ok
+
-
mode

Μπορείτε να ρυθμίσετε κοινό χρονοπρόγραμμα για τις Δευτέρα – Παρασκευή και κοινό για Σάββατο - Κυριακή.

Παράδειγμα:

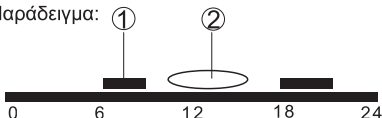

- ① Ορατοί τομείς: έλεγχος σε θερμοκρασία Άνεσης
② Αόρατοι τομείς: έλεγχος σε θερμοκρασία εξοικονόμησης

Proceed as follows:

- 1) Ρυθμίστε την παράμετρο (P11=2). Βλέπε τμήμα " **Επιθυμείτε να αλλάξετε τις παραμέτρους**".
- 2) Πιέστε **set** και επιλέξτε  _{AUTO}.
- 3) Πιέστε **ok** για επιβεβαίωση.
- 4) Εμφανίζεται το χρονοπρόγραμμα για Δευτ (1) - Παρ(5).
- 5) Πιέστε **+** ή **-** για επιλογή περιόδου, Δευτ (1) - Παρ(5) ή Σάβ (6) - Κυρ (7).
- 6) Πιέστε **ok** για να επιβεβαιώσετε την επιλεγμένη περίοδο και να προγραμματίσετε τις ώρες λειτουργίας.

Κατά τη διάρκεια των βημάτων προγραμματισμού:

- 7) Πιέστε **mode** για να επιλέξετε τρόπο λειτουργίας, (Άνεσης ή Εξοικονόμησης) ή
- 8) Πιέστε **+** ή **-** για να θέσετε το χρόνο διάρκειας (ανά 15 λεπτά) του επιλεγμένου τρόπου λειτουργίας.
- 9) Πιέστε **ok** για να αποθηκεύσετε το χρονοπρόγραμμα.
- 10) Επαναλάβετε τα βήματα 5-9 και για την άλλη περίοδο (αν απαιτείται) διαφορετικά
- 11) Πιέστε **mode** ή περιμένετε κάποιο χρονικό διάστημα για αυτόματη έξοδο.

Εργοστασιακή ρύθμιση 7-ήμερου χρονοπρογράμματος

Αρχική τιμή	Ημέρα/ες	Λειτουργία Άνεσης	Λειτουργία Εξοικονόμησης
	Δε (1) – Πα (5)	6:00 – 8:00 hr 17:00 – 22:00 hr	22:00 – 6:00 hr 8:00 – 17:00 hr
	Σα (6) – Κυρ (7)	7:00 – 22:00 hr	22:00 – 7:00 hr



EL

Εμφανίζεται το σύμβολο στην οθόνη; (Μόνο για τις εκδόσεις με μπαταρίες)

Το σύμβολο  εμφανίζεται όταν απαιτείται αντικατάσταση των μπαταριών.

- Πάρτε 2 νέες αλκαλικές μπαταρίες τύπου AAA
- Αφαιρέστε τη θήκη των μπαταριών, στη συνέχεια τις μπαταρίες, εισάγετε τις νέες μπαταρίες, εντός 1,5 λεπτών, τοποθετήστε ξανά τη θήκη μπαταριών.
- Βεβαιωθείτε πως οι παλιές μπαταρίες απορρίπτονται σύμφωνα με τις περιβαλλοντικές απαιτήσεις

Επιθυμείτε να αλλάξετε τις παραμέτρους;

+ - ok 	<ul style="list-style-type: none">• Πιέστε + και - ταυτόχρονα για 5 sec• Ελευθερώστε τα και εμφανίζεται η "P01"• Πιέστε + ή - για επιλογή παραμέτρου• Πιέστε ok για να ρυθμίσετε την τιμή και ξανά για επιβεβαίωση• Πιέστε  για έξοδο ή περιμένετε κάποιο χρονικό διάστημα για επιστροφή στην αρχική οθόνη
--	--

Λίστα παραμέτρων

EL

Αριθμός παραμέτρου	Περιγραφή	Εύρος ρύθμισης (εργοστασιακή)
P01	Ένδειξη ώρας	1 = 24:00 (εργοστ.) 2 = 12:00 AM/PM
P02	Επιλογή °C ή °F	1 = °C (εργοστασιακή) 2 = °F
P03	Βασική ένδειξη θερμοκρασίας	1 = θερμοκρασία χώρου (εργοστ.) 2 = επιθυμητή θερμοκρασία
P04	Βαθμονόμηση αισθητηρίου θερμοκρασίας	-3...3 °C Βήμα 0.5 °C (-6...6 °F, βήμα 1 °F) Εργοστασιακή: 0 °C
P06	Κλειδίωμα επιθυμητής θερμοκρασίας Άνεσης	0 = OFF (εργοστασιακή) 1 = ON → κλειδωμένη σύμφωνα με τη ρύθμιση της μόνιμης επιθυμητής
P08	Κλειδίωμα επιθυμητής θερμοκρασίας Εξοικονόμησης	0 = OFF (εργοστασιακή) 1 = ON → κλειδωμένη σύμφωνα με τη ρύθμιση της μόνιμης επιθυμητής
P09	Buzzer	0 = OFF 1 = ON (εργοστασιακή)
P10	Εμφάνιση συμβόλου αντιπαγετικής προστασίας	0 = OFF (εργοστ.) 1 = ON
P11	Τύπος χρονοπρογράμματος	0 = Ανεξάρτητα για κάθε ημέρα (εργοστ.) 1 = Κοινό για τις 7 ημέρες. 2 = 5/2 ημέρες
P12	Περιοδικές εκκινήσεις του κυκλοφορητή	0 = OFF (εργοστ.) 1 = ON

P14	X1 Εξωτερική είσοδος (μόνο για RDE100.1)	0 = Καμία 1 = Εξωτερικό αισθητήριο 2 = Ψηφιακή είσοδος
P15	Όριο θερμοκρασίας (μόνο για RDE100.1)	0 = OFF (εργοστ.) 1 = ON
P16	Μέγιστο όριο θερμ. για ενδοδαπέδια θέρμανση (μόνο για RDE100.1)	25...60 °C, βήμα 1 °C ή 77...140 °F, βήμα 1 °F Εργοστασιακή: 30 °C
P17	Επαφή παραθύρου (μόνο για RDE 100.1)	0 = Κανονικά Ανοιχτή (εργοστ.) 1 = Κανονικά Κλειστή
P21	Ρυθμός σάρωσης πίνακα αφής κατά τη διάρκεια του χρόνου αδρανείας (RDE100.1 μόνο) Σημείωση: υψηλός ρυθμός σημαίνει μικρότερη διάρκεια ζωής για τις μπαταρίες.	0.2 = 0.25 s 0.5 = 0.5 s 1.0 = 1.0 s (εργοστ.) 1.5 = 1.5 s
P22	Επαναφορά εργοστασιακών ρυθμίσεων	0 = OFF (εργοστασιακή) 1 = επαναφορά
P23	Έκδοση λογισμικού	Δεν είναι δυνατή η ρύθμιση
P78	Συμπεριφορά ελέγχου	0 = On/Off, 1.0K 1 = On/Off, 0.3K 2 = TPI γρήγορος 3 = TPI μέσος 4 = TPI αργός (εργοστ.)
P89	Μέγιστος χρόνος πρώρης εκκίνησης	0, 0.5,...24 h Εργοστασιακή: 0 h
P90	Μέγιστος χρόνος πρώρης διακοπής	0, 0.5,...6 h Εργοστασιακή: 0 h

Απόρριψη αποβλήτων ηλεκτρονικού εξοπλισμού με μπαταρία

EL



Η συσκευή ως προς την απόρριψή της έχει ταξινομηθεί ως απόβλητο ηλεκτρονικού εξοπλισμού σύμφωνα με την Ευρωπαϊκή Οδηγία 2012/19/ΕΕ και δεν επιτρέπεται να απορρίπτεται μαζί με τα οικιακά απορρίμματα.

- Απορρίπτετε τη συσκευή μέσω των δικτύων που έχουν οριστεί.
- Τηρείτε την τοπική ισχύουσα νομοθεσία.
- Απορρίπτετε τις χρησιμοποιημένες μπαταρίες στα κέντρα συλλογής που έχουν οριστεί για το σκοπό αυτό.

CS Návod k obsluze

RDE100.. – elektronický regulátor umožňující nastavit požadovanou prostorovou teplotu kdykoliv si přejete. K dispozici je několik spínacích šablon, které je možné přizpůsobit podle vašich individuálních potřeb.

CS



1. Displej

-  Symbol vybitých baterií (pouze verze napájené bateriemi)
-  Ochrana proti zamrznutí (vytápění) je aktivní
-  Automatický režim
-  Zobrazení a nastavení časového programu
-  Komfortní režim
-  Útlumový režim
-  Opustit menu
-  Aktivace externího vstupu
-  Nastavení trvalé žádané teploty
-  Nastavení dne a času
-  Nastavení prázdninového režimu



Zobrazení času

am

Dopoledne: 12-ti hodinový formát

pm

Odpoledne: 12-ti hodinový formát



ALL

Potvrzení

°F

Prostorová teplota ve stupních Fahrenheita

°C

Prostorová teplota ve stupních Celsia



Ovládací tlačítka uzamknuta



Zobrazení prostorové teploty, žádané teploty, atd.



Vytápění ZAP



1 = Pondělí / 7 = Neděle



Časová osa



Aktuální prostorová teplota

2. Mode - změna druhu provozu

3. Set - nastavení

4. Ok - potvrzení hodnoty

5. Snížení hodnoty

6. Zvýšení hodnoty

7. Držák baterií

Chcete nastavit čas a den?

set	Postupujte následovně:
ok	<ul style="list-style-type: none">• Stiskněte set a vyberte 🕒
+	<ul style="list-style-type: none">• Stiskněte ok, bliká zobrazení času
-	<ul style="list-style-type: none">• Pro nastavení času stiskněte + nebo -
mode	<ul style="list-style-type: none">• Stiskněte ok pro potvrzení• Bliká den v týdnu, tlačítkem + nebo - vyberte požadovaný den• Stiskněte ok pro uložení• Stiskněte mode pro opuštění menu nebo počkejte, až regulátor opustí menu automaticky

CS

Chcete uzamknout ovládací tlačítka?





mode	<p>Pro uzamknutí ovládacích tlačítek stiskněte a podržte tlačítko mode alespoň na 7 sekund. Pro odemknutí postupujte stejně.</p> <p>Když jsou tlačítka uzamknuta, pracuje regulátor normálně. Není ale možné provádět jakékoliv změny nastavení, dokud se tlačítka opět neodemknou.</p>
-------------	--

Je vám příliš horko nebo chladno?

+	Stisknutím tlačítek + nebo - můžete dočasně zvýšit nebo snížit žádanou teplotu v krocích po 0,5 °C / 1 °F. Postupujte následovně:
-	
ok	<ul style="list-style-type: none">• K nastavení žádané teploty stiskněte + nebo -. S následující změnou druhu provozu se toto nastavení vrátí na původní hodnotu.• Stiskněte ok, set nebo mode pro uložení hodnoty nebo počkejte, dokud regulátor neopustí menu automaticky.• Pro uzamknutí žádaných teplot použijte parametry P05 a P07.
set	
mode	

Chcete změnit druh provozu?

CS

mode	<p>Termostat nabízí Komfortní režim, Útlumový režim, Automatický režim. Přepnutí mezi provozními režimy lze ručně provést tlačítkem mode.</p> <p> Komfortní režim je trvalá regulace (24 h) na komfortní žádanou teplotu (např. 20 °C). Tento režim vyberte, jestliže chcete udržovat komfortní teplotu nepřetržitě bez časového programu. Používá se například během přítomnosti uživatele.</p> <p> Útlumový režim je trvalá regulace (24 h) na útlumovou žádanou teplotu (např. 18 °C). Tento režim vyberte, jestliže chcete udržovat útlumovou teplotu nepřetržitě bez časového programu. Používá se během nepřítomnosti uživatele, nebo například v noci.</p> <p> AUTO V automatickém režimu regulátor automaticky přepíná mezi Komfortní a Útlumovou teplotou podle nastaveného časového programu.</p> <p>! Poznámka: Ochrana proti zamrznutí je funkce, která je v pozadí stále aktivní. Jakmile prostorová teplota poklesne pod 5 °C, regulátor automaticky aktivuje vytápění .</p>
-------------	--

Chcete nastavit trvalé žádané teploty?



set ok + - mode	<ul style="list-style-type: none">• Stiskněte set a vyberte • Stiskněte ok pro potvrzení• Stiskněte mode pro výběr provozního režimu, Komfort nebo Útlum• Stiskněte + nebo - k nastavení trvalé žádané teploty.• Stiskněte ok pro potvrzení• Stiskněte mode pro opuštění menu nebo počkejte, až regulátor opustí menu automaticky
--	---

! **Poznámka:** Tyto trvalé žádané teploty se používají během Automatického režimu s časovým programem.

 **Typy na úspory bez ztráty komfortu**

- Během topné sezóny zvolte Automatický režim a nastavte časový program podle běžného provozu vaší domácnosti
- Při delší nepřítomnosti a v letním období nastavte Útlumový režim

Chcete nastavit prázdninový režim?

<p>set ok + - mode</p>	<p>Prázdninový režim použijte k nastavení regulátoru na konstantní teplotu během vaší nepřítomnosti.</p> <ul style="list-style-type: none"> • Stiskněte set a vyberte  • Stiskněte ok pro potvrzení • Stiskněte + nebo - pro nastavení žádané teploty • Stiskněte ok pro potvrzení • Tlačítka + nebo - nastavte, kolik dnů budete na dovolené (Poznámka: 0 = Prázdninový režim VYP) • Stiskněte ok pro uložení • Jakmile se aktivuje prázdninový režim, zobrazí se na displeji zbývající dny <p>! Poznámka: Pokud se během prázdninového režimu stiskne tlačítko mode, funkce se vypne a zmizí symbol  .</p> <p>Pokud jsou obě hodnoty komfortní a útlumové žádané teploty uzamčeny, je nejnižší uzamčená hodnota žádaná teplota pro prázdninový režim. Žádanou teplotu můžete nastavit od 5 °C do nejnižší uzamknuté hodnoty žádané teploty.</p>
---	---

Chcete nastavit svůj vlastní časový program?

Varianta 1: Rozdílný časový program pro každý den v týdnu (P11=0)

CS

set
ok
+
-
mode

Každému 15–ti minutovému intervalu během dne můžete přiřadit Komfortní nebo Útlumový režim. Časová osa 0:00 až 24:00 hodin vám umožní nastavit druhy provozu během celého vybraného dne (dnů).

Příklad:

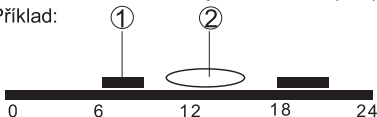

① Zobrazené segmenty: Regulace na Komfort

② Nezobrazené segmenty: Regulace na Útlum

Pokud je vybraný Automatický režim s časovým programem, budou se provozní režimy automaticky přepínat, jakmile se nastavený program uloží.

Postupujte následovně:

- 1) Stiskněte **set** a vyberte  **AUTO**.
- 2) Stiskněte **ok** pro potvrzení.
- 3) Zobrazí se časový program pro Po (1).
- 4) Stiskněte **+** nebo **-** pro výběr dne od Po (1) do Ne (7).
- 5) Stiskněte **ok** pro potvrzení zvoleného dne a pro začátek programování spínacích časů.

Programování spínacích časů:

- 6) Stiskněte **mode** pro výběr provozního režimu, (Komfort nebo Útlum) **nebo**
- 7) Pro výše vybraný provozní režim nastavte tlačítka **+** nebo **-** v krocích po 15 minutách časový program.
- 8) Stiskněte **ok** pro uložení časového programu.
- 9) Opakujte kroky 4-8 pro ostatní zbývající dny (pokud je třeba); nebo
- 10) Stiskněte **mode** pro opuštění menu nebo počkejte, až regulátor opustí menu automaticky.

Varianta 2: Stejný časový program pro všech 7 dnů (P11=1)

set
ok
+
-
mode

Pro všech 7 dnů můžete časový program nastavit najednou.

Příklad:

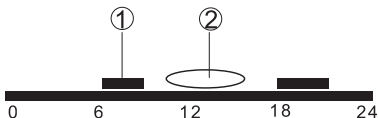

① Zobrazené segmenty: Regulace na Komfort

② Nezobrazené segmenty: Regulace na Útlum

Postupujte následovně:

- 1) Nastavte parametr (P11=1). Viz. část „**Chcete změnit regulační parametry?**“
- 2) Stiskněte **set** a vyberte  AUTO.
- 3) Stiskněte **ok** pro potvrzení.
- 4) Zobrazí se časový program pro Po (1) – Ne (7).
- 5) Stiskněte **ok** pro začátek nastavení časového programu.

Programování spínacích časů:

- 6) Stiskněte **mode** pro výběr provozního režimu, (Komfort nebo Útlum) **nebo**
- 7) Pro výše vybraný provozní režim nastavte tlačítka **+** nebo **-** v krocích po 15 minutách časový program.
- 8) Stiskněte **ok** pro uložení časového programu.
- 9) Stiskněte **mode** pro opuštění menu nebo počkejte, až regulátor opustí menu automaticky.

CS

Varianta 3: Časový program pro 5 a 2 dny (P11=2)

CS

set
ok
+
-
mode

Časový program můžete nastavit najednou pro Pondělí až Pátek a pro Sobotu a Neděli.

Příklad:

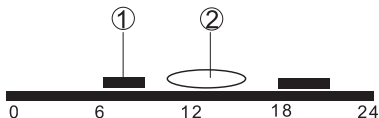

① Zobrazené segmenty: Regulace na Komfort

② Nezobrazené segmenty: Regulace na Útlum

Postupujte následovně:

- 1) Nastavte parametr (P11=2). Viz. část „**Chcete změnit regulační parametry?**“
- 2) Stiskněte **set** a vyberte  AUTO.
- 3) Stiskněte **ok** pro potvrzení.
- 4) Zobrazí se časový program pro Po (1) – Ne (5).
- 5) Stiskněte **+** nebo **-** pro výběr časového intervalu, Po (1) až Pá (5) nebo So (6) až Ne (7).
- 6) Stiskněte **ok** pro potvrzení zvoleného časového intervalu a pro začátek programování spínacích časů.

Programování spínacích časů:

- 7) Stiskněte **mode** pro výběr provozního režimu, (Komfort nebo Útlum) **nebo**
- 8) Pro výše vybraný provozní režim nastavte tlačítka **+** nebo **-** v krocích po 15 minutách časový program.
- 9) Stiskněte **ok** pro uložení časového programu.
- 10) Opakujte kroky 5-9 pro ostatní časové intervaly (pokud je třeba); nebo
- 11) Stiskněte **mode** pro opuštění menu nebo počkejte, až regulátor opustí menu automaticky.

Tovární nastavení týdenního časového programu

Nastavení z výroby	Den/dny	Komfortní režim	Útlumový režim
	Po (1) – Pá (5)	6:00 – 8:00 hod 17:00 – 22:00 hod	22:00 – 6:00 hod 8:00 – 17:00 hod
	So (6) – Ne (7)	7:00 – 22:00 hod	22:00 – 7:00 hod

CS

Zobrazil se na displeji symbol ?

(Pouze pro verze napájené bateriemi)

Symbol  se zobrazí, jestliže jsou vybité baterie. Vyměňte je za 2 nové alkalické baterie typu AAA. Postupujte následovně:

- Vezměte 2 nové alkalické baterie typu AAA.
- Vysuňte držák baterií, vyjměte baterie, vložte nové baterie a do 1,5 minut zasuňte držák baterií zpět
- Vybité baterie likvidujte v souladu s předpisy pro nakládání s nebezpečnými odpady.

Chcete změnit nastavení regulačních parametrů?

+ - ok mode	<p>Jestliže chcete změnit regulační parametry, postupujte následovně:</p> <ul style="list-style-type: none">• Stiskněte na 5 sekund současně tlačítka + a -• Uvolněte je, v dolní části se zobrazí parametr "P01"• Tlačítka + nebo - vyberte parametr, který chcete upravit• Tlačítkem ok potvrďte výběr tohoto parametru• Tlačítkem + nebo - nastavte hodnotu• Tlačítkem ok potvrďte a uložte nastavenou hodnotu• Stiskněte mode pro opuštění menu úpravy parametrů bez uložení nastavených hodnot nebo počkejte, dokud regulátor neopustí menu automaticky
--	---

Seznam regulačních parametrů

Parametr č.	Popis	Rozsah nastavení (tovární nastavení)
P01	Formát času	1 = 24:00 hod (tovární nastavení) 2 = 12:00 AM/PM
P02	Volba °C nebo °F	1 = °C (tovární nastavení) 2 = °F
P03	Zobrazení teploty na displeji	1 = prostorová teplota (tovární nastavení) 2 = žádaná teplota
P04	Kalibrace teplotního čidla	-3...3 °C V krocích po 0,5 °C (-6...-14,44 °C, po 1 °F) Nastavení z výroby: 0 °C
P06	Uzamknutí komfortní žádané teploty	0 = VYP (tovární nastavení) 1 = ZAP → uzamknutí trvalé žádané teploty
P08	Uzamknutí útlumové žádané teploty	0 = VYP (tovární nastavení) 1 = ZAP → uzamknutí trvalé žádané teploty
P09	Akustická signalizace	0 = VYP 1 = ZAP (tovární nastavení)
P10	Zobrazení symbolu Ochrany proti zamrznutí	0 = VYP (tovární nastavení) 1 = ZAP
P11	Typ časového programu	0 = Jednotlivé dny (tovární nastavení) 1 = Všech 7 dnů stejně 2 = 5 - 2 dny stejně
P12	Pravidelné protočení čerpadla (ochrana proti zatuhnutí)	0 = VYP (tovární nastavení) 1 = ZAP

P14	X1 Externí vstup (pouze RDE100.1)	0 = Nepoužívá se 1 = Oddělené teplotní čidlo 2 = Digitální vstup
P15	Omezení teploty (pouze RDE100.1)	0 = VYP (tovární nastavení) 1 = ZAP
P16	Omezení maximální teploty pro podlahové vytápění (pouze RDE100.1)	25...60 °C, po 1 °C nebo 77...140 °F, po 1 °F Nastavení z výroby: 30 °C
P17	Okenní spínač, typ kontaktů (pouze RDE 100.1)	0 = Spínací (NO) (tovární nastavení) 1 = Rozpínací (NC)
P21	Interval snímání dotykových tlačítek (pouze pro RDE100.1) Poznámka: Častější snímání dotykových tlačítek snižuje životnost baterií.	0.2 = 0,25 s 0.5 = 0,5 s 1.0 = 1,0 s (tovární nast.) 1,5 = 1,5 s
P22	Návrat k továrnímu nastavení	0 = VYP (tovární nastavení) 1 = Reset na tovární hodnoty
P23	Informace o verzi software	Není možné žádné nastavení
P78	Regulační algoritmus	0 = Zap/Vyp, 1.0K 1 = Zap/Vyp, 0.3K 2 = PI Rychly 3 = PI Střední 4 = PI Pomaly (tovární nastavení)
P89	Optimalizace zapnutí	0, 0.5,...24 h Nastavení z výroby: 0 h
P90	Optimalizace vypnutí	0, 0.5,...6 h Nastavení z výroby: 0 h

CS

Likvidace odpadních elektrických a elektronických zařízení s baterií

CS



Přístroj se při likvidaci považuje za odpadní elektrické a elektronické zařízení ve smyslu Evropské směrnice 2012/19/EU a nesmí se likvidovat jako domovní odpad.

- Likvidujte přístroj prostřednictvím k tomu určených kanálů.
- Dodržujte místní a aktuálně platnou legislativu.
- Spotřebované baterie likvidujte na k tomu určených sběrných místech.

hu Kezelési leírás

RDE100.. – a helyiségtermosztát, mely lehetővé teszi Ön számára az ideális hőmérséklet beállítását bármely időpontra.

Az egyedi időprogram szerinti működésnek köszönhetően a helyiség hőmérséklet mindig az Ön egyedi igényeinek megfelelően állítható be kényelmesen és egyszerűen.

HU

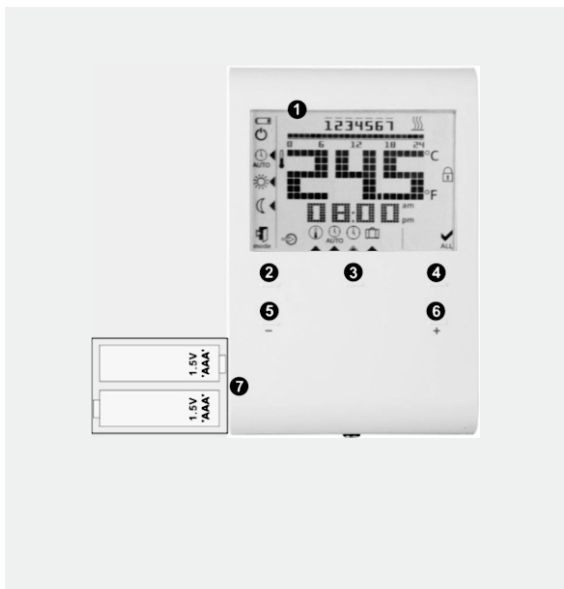

1. Kijelző

Elemcsere
szükségességét jelző
szimbólum (csak az
elemes tápellátású
kiviteleknel)



Fagyvédelem aktív
(fűtés)



Időprogram szerinti
üzemmód
Automatikus
Időprogram
megjelenítése és
beállítása



Komfort üzemmód



Energiatakarékos
üzemmód



Kilépés



Külső bemenet
engedélyezve



Állandó alapjel
beállítás



Nap és óra beállítása



Szabadság
üzemmód beállítása



Idő megjelenítése

am

Délelőtt: 12-órás
formátum

pm

Délután: 12-órás
formátum



Nyugtázás (OK)



Helyiség hőmérsékli
et Fahrenheit
fokban



Helyiség hőmérsékli
et Celsius fokban



Billentyűzár
aktiválva



Helyiség hőmérséklet,
alapjel, stb. kijelzése.



Fűtés BE



Hét napjai

1 = Hétfő

7 = Vasárnap



Idősáv



Aktuális helyiség
hőmérséklet

2. Mode (Üzemmód átkapcsolása)

3. Set (Beállítás)

4. OK

5. Érték csökkentése

6. Érték növelése

7. Elemtartó

Szeretné beállítani a napot és a pontos időt?

set	Végezze el az alábbi műveleteket:
ok	<ul style="list-style-type: none">• Nyomja meg a set –gombot és válassza ki a -t
+	<ul style="list-style-type: none">• Nyomja meg az ok –gombot, ezután az idő villogni kezd, jelezve hogy a beállítás megkezdhető
–	<ul style="list-style-type: none">• Nyomja meg a + vagy – gombot és állítsa be a kívánt időpontot
mode	<ul style="list-style-type: none">• Nyomja meg az ok gombot a megerősítéshez• A hét napjai villognak, nyomja le a + vagy – gombot a megfelelő nap kiválasztásához• Nyomja meg az ok gombot a beállítások elmentéséhez• Nyomja meg a mode gombot a kilépéshez, vagy várjon egy kicsit az automatikus kilépésig

HU

Szeretné lezárni a gombokat?

mode	Tartsa lenyomva a mode gombot minimum 7 másodpercig. Ez aktiválja a billentyűzár funkciót. A kioldáshoz tegye meg ugyanezt ismét. A készülék továbbra is zavartalanul működik, a billentyűzár aktív időtartama alatt is, viszont nem lehetséges a készüléken semmiféle beavatkozás, amíg a billentyűzár funkciót ki nem kapcsolják.
-------------	--

Túl meleg/hideg van a helyiségben?

+	Ezen gombok lenyomásával, a kívánt alapjel értéke növelhető/csökkenthető 0.5 °C / 1 °F-os lépésekben. Az eljárás a következő:
–	
ok	<ul style="list-style-type: none">• Nyomja le a + vagy – gombot az alapjel értékének ideiglenes megváltoztatásához.
set	Ez a változtatás azonnal törlésre kerül, amint üzemmódot váltanak a készüléken.
mode	<ul style="list-style-type: none">• Ezután vagy várjon egy kicsit az érték automatikus mentéséig, vagy azonnal elmentheti a beállított értéket az ok, set vagy a mode gomb lenyomásával• Az alapjel érték a paraméter beállításoknál zárolható

Szeretné átkapcsolni az üzemmódot?

mode A termosztát rendelkezik Komfort üzemmód, Energiatakarékos üzemmód, Automatikus időprogram szerinti üzemmód. Az átváltás az egyes üzemmódok között elvégezhető a **mode** gomb lenyomásával.



A **Komfort üzemmód** a beállított Komfort alapjel érték (gyári beállított érték 20°C) folyamatos (24 h) tartását jelenti. Ezt az üzemmódot akkor kell választani, amikor folyamatosan fenn kívánjuk tartani a Komfort hőfokot, például a helyiségben való tartózkodás időtartamára.



Az **Energiatakarékos üzemmód** a beállított Energiatakarékos alapjel érték (gyári beállított érték 16°C) folyamatos (24 h) tartását jelenti. Ezt az üzemmódot akkor kell választani, amikor folyamatosan fenn kívánjuk tartani a csökkentett Energiatakarékos hőfokot, például a távollét, vagy az éjszakai (alvási) időszak időtartamára.



Automatikus időzítés szerinti üzemmódban a készülék az egyes üzemmódok között (Komfort, Energiatakarékos) automatikusan vált át a beállított időprogramnak megfelelően.



Tudnivaló:

A **Fagyvédelmi üzemmód** funkció mindig aktív a háttérben. Amint a helyiség hőmérséklet 5 °C alá esik, a készülék automatikusan aktiválja a fűtést .

Szeretné beállítani az állandó hőmérsékleti alapjel értékeket?

set	<ul style="list-style-type: none">• Nyomja meg a set gombot és válassza ki a -t• Nyomja meg az ok -t a megerősítéshez• Nyomja meg a mode gombot a kívánt üzemmód kiválasztásához (Komfort vagy Energiatakarékos)• Állítsa be a kívánt hőfokot a + vagy - gombok lenyomásával.• Nyomja meg az ok -t a megerősítéshez
ok	
+	
-	
mode	
	Nyomja le a mode -ot a kilépéshez vagy várjon egy kicsit



az automatikus kilépés bekövetkezéséig

Tudnivaló: Ezeket az állandó alapjel értékek váltakoznak automatikus időprogram szerinti üzemmódban.



Energiatakarékossági tippek komfortvesztés nélkül

HU

- Válassza az időprogram szerinti működést a fűtés szabályozására, és az időprogramot a saját életvitele szerint állítsa be
- Amikor hosszabb ideig távol van, akkor kapcsolja át a készüléket Energiatakarékos üzemmódba, illetve a hosszabb szabadságok idejére Szabadság üzemmódba

Szeretné beállítani a Szabadság üzemmódot?

set ok + - mode	<p>Szabadság üzemmódban a termosztát egy előre beállított állandó hőmérsékletet tart, a szabadság beállított időtartama alatt.</p> <ul style="list-style-type: none">• Nyomja meg a set gombot és válassza a -t• Nyomja meg az ok -t a megerősítéshez• Nyomja meg a + vagy - -t a kívánt alapjel érték beállításához• Nyomja meg az ok -t a megerősítéshez• Ezután ismét nyomja le a + vagy - gombot a szabadás hosszának megfelelő napok beállításához (Tudnivaló: 0 = Szabadság üzemmód OFF (KI))• Nyomja meg az ok -t az érték elmentéséhez• Miután a Szabadság üzemmód aktiválásra kerül, a hátralévő napok száma látható a kijelzőn <p>Tudnivaló: Ha lenyomja a mode gombot a Szabadság üzemmód működése alatt, a funkció kikapcsol és a ikon eltűnik a kijelzőről.</p> <p>Ha a Komfort és az Energiatakarékos alapjel érték is zárrolva van, a legalacsonyabb zárolt alapjel érték lesz a Szabadság üzemmód alapjel értéke. Az alapjel értéket 5 °C-tól a legalacsonyabb zárolt hőfok értékéig lehet állítani.</p>
--	---

Szeretné beállítani a saját időprogramját?

1. lehetőség: Időprogram egyedi napokkal (P11=0)

HU

set

ok

+

-

mode

A Komfort és Energiatakarékos üzemmódok között át lehet váltani 15 perces intervallumokban. A 0:00 ... 24:00 időszáv lehetővé teszi a kívánt időprogram beállítását a kívánt nap(ok)ra.

Példa:

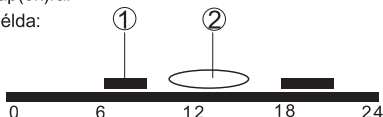

① Látható szegmens: Komfort hőmérséklet aktív

② Hiányzó szegmens: Energiatakarékos hőmérséklet aktív

Ha a beállítások elmentésre kerülnek, az átváltás az üzemmódok között automatikusan bekövetkezik, amennyiben az Automatikus Időprogram szerinti üzemmód aktiválva van.

Az eljárás a következő:

- 1) Nyomja meg a **set** gombot és válassza az -t.
- 2) Nyomja meg az **ok -t** a megerősítéshez
- 3) Az időprogram a Hétfői (1) napnál látható.
- 4) Nyomja meg a **+** vagy **-**-t a nap kiválasztásához, Hétfőtől (1) Vasárnapig (7).
- 5) Nyomja meg az **ok -t** a kiválasztott nap megerősítéséhez, az időprogram bevitelének megkezdéséhez

A programozási lépések a következők:

- 6) Nyomja meg a **mode** gombot egy működési mód kiválasztásához, (Komfort / Energiatakarékos) **és**
- 7) Állítsa be a fent kiválasztott üzemmódhoz tartozó kapcsolási időpontokat a **+** vagy **-** gombokkal 15 perces lépésekben.
- 8) Nyomja meg az **ok -t** a fenti időprogram elmentéséhez.
- 9) Ismétlje meg a 4-8 pontokat a többi hátralévő napra is (ha szükséges); egyébként
- 10) Nyomja meg a **mode** gombot vagy várjon egy kicsit az automatikus kilépés bekövetkezéséig.

2. lehetőség: Beállítás 7 napra azonos időprogrammal (P11=1)

set
ok
+
-
mode

Lehetséges mind a 7 napra ugyanazon időprogramot alkalmazni.

Példa:

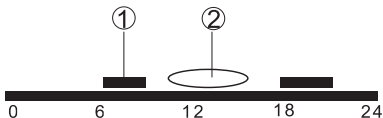

- ① Látható szegmens: Komfort hőmérséklet aktív
- ② Hiányzó szegmens: Energiatakarékos hőmérséklet aktív

Az eljárás a következő:

- 1) Állítsa be a paramétert (P11=1). Lásd "**Meg szeretné változtatni a paramétereiket**" fejezetet.
- 2) Nyomja meg a **set** gombot és válassza az  AUTO-t.
- 3) Nyomja meg az **ok -t** a megerősítéshez
- 4) Az időprogram a Hétfő (1) - Vasárnap (7) periódusra látható a kijelzőn.
- 5) Nyomja meg az **ok-t** az időprogram bevitelének megkezdéséhez.

A programozási lépések a következők:

- 6) Nyomja meg a **mode** gombot egy működési mód kiválasztásához, (Komfort / Energiatakarékos) **és**
- 7) Állítsa be a fent kiválasztott üzemmóddhoz tartozó kapcsolási időpontokat a **+** vagy **-** gombokkal 15 perces lépésekben.
- 8) Nyomja meg az **ok -t** a fenti időprogram elmentéséhez.
- 9) Nyomja meg a **mode** gombot vagy várjon egy kicsit az automatikus kilépés bekövetkezéséig.

3. lehetőség: Beállítás 5 / 2 napos időprogrammal (P11=2)

set
ok
+
-
mode

A kapcsolási időpontok beállíthatók egyrészt egy Hétfő – Péntek, másrészt egy Szombat – Vasárnap időszakra vonatkozó időprogrammal.

Példa:

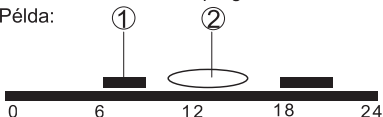

- ① Látható szegmens: Komfort hőmérséklet aktív
- ② Hiányzó szegmens: Energiatakarékos hőmérséklet aktív

Az eljárás a következő:

- 1) Állítsa be a paramétert (P11=2). Lásd "**Meg szeretné változtatni a paramétereiket**" fejezet.
- 2) Nyomja meg a **set** gombot és válassza az  AUTO-t
- 3) Nyomja meg az **ok** -t a megerősítéshez.
- 4) Az időprogram a Hétf.(1) – Pént.(5) periódusra látható.
- 5) Nyomja meg a **+** vagy **-** -t a Hétf. (1) – Pént.(5) vagy Szomb. (6) – Vas. (7) periódus kiválasztásához.
- 6) Nyomja meg az **ok** -t a periódus megerősítéséhez és az időprogram bevitelének megkezdéséhez.

A programozási lépések a következők:

- 7) Nyomja meg a **mode** gombot egy működési mód kiválasztásához, (Komfort / Energiatakarékos) és
- 8) Állítsa be a fent kiválasztott üzemmódhoz tartozó kapcsolási időpontokat a **+** vagy **-** gombokkal 15 perces lépésekben.
- 9) Nyomja meg az **ok** -t a fenti időprogram elmentéséhez.
- 10) Ismétlje meg az 5-9 lépéseket a másik periódushoz ha szükséges, egyébként
- 11) Nyomja meg a **mode** gombot vagy várjon egy kicsit az automatikus kilépés bekövetkezéséig.

A 7-napos időprogram gyári beállítási értékei

Gyári érték	Nap(ok)	Komfort mód	Energiatakarékos mód
	Hétfő(1) – Péntek (5)	6:00 – 8:00 17:00 – 22:00	22:00 – 6:00 8:00 – 17:00
Szombat(6) – Vas.(7)	7:00 – 22:00	22:00 – 7:00	

HU

A szimbólum látszik a kijelzőn? (Csak elemes tápellátású kiviteleknel)

A  szimbólum akkor látható a kijelzőn, amikor az elemcsere szükségessé vált. Cserélje ki az elemeket 2db új AAA típusú alkáli elemre. Az alábbiakat kell tennie:

- Szerezzen be 2db új AAA típusú alkáli elemet
- Húzza ki az elemtartó tálcát, vegye ki a régi elemeket, tegye be az újakat és illessze vissza az elemtartó tálcát a helyére 1,5 percen belül
- Gondoskodjon arról, hogy a használt elemeket a környezetvédelmi előírásoknak megfelelően, biztonságosan kezeljék, illetve ártalmatlanítsák
- Elemcsere esetén az elemek eltávolítása után a készülék a pontos idő kivételével minden adatot korlátlan ideig tárol. A pontos időt az elemek eltávolítása után kb. 1,5 percig tárolja.

Meg szeretné változtatni a paramétereiket?

+ – ok mode	Ha szeretné megváltoztatni a szabályozási paramétereiket, tegye a következőket: <ul style="list-style-type: none">• Nyomja le a + és – gombokat egyszerre 5 másodpercig• Engedje fel azokat és a "P01" paraméter látható az alsó szegmensben• Nyomja meg a + vagy – gombokat a kívánt paraméter kiválasztásához• Nyomja meg az ok-t a kívánt paraméter kiválasztásához• A + vagy – gombbal állítsa be az adott paraméter értékét• Nyomja meg a ok-t a beállított érték elmentéséhez• Ugyanígy válassza ki és állítsa be a többi paramétert is• Nyomja le a mode gombot a paramétereiből történő mentés nélküli kilépéshez, vagy várjon egy kis időt, amíg a program automatikusan kilép
--------------------------------	---

Paraméter lista

Paraméter száma	Leírás	Állítási tartomány (gyári érték)
P01	Idő formátuma	1 = 24:00 órás (gyári ért.) 2 = 12:00 AM/PM
P02	°C vagy °F kiválasztása	1 = °C (gyári érték) 2 = °F
P03	Standard hőmérséklet kijelzés	1 = helyiség hőmérséklet (gyári érték) 2 = alapjel
P04	Hőmérséklet-érzékelő kalibrálása	-3...3 °C 0.5 °C-os lépésekben (-6...6 °F, 1 °F-es lép.-ben) Gyári érték: 0 °C
P06	Komfort alapjel zárolása	0 = OFF (gyári érték) 1 = ON → zárolt az állandó hőmérsékleti alapjelnél beállított értéknek megfelelően
P08	Energiatakarékos alapjel zárolása	0 = OFF (gyári érték) 1 = ON → zárolt az állandó hőmérsékleti alapjelnél beállított értéknek megfelelően
P09	Jelző (hang)	0 = OFF 1 = ON (gyári érték)
P10	Fagyvédelmi ikon megjelenítése	0 = OFF (gyári érték) 1 = ON
P11	Időprogram típusa az automatikus időprogram szerinti működéshez	0 = Egyedi napok (gyári érték) 1 = 7 napra azonos 2 = 5/2 napos időprogr.
P12	Periodikus szivattyú járatás	0 = OFF (gyári érték) 1 = ON

P14	X1 Külső bemenet (csak RDE100.1-nél)	0 = Nincs bemenet 1 = Külső érzékelő 2 = Digitális bemenet
P15	Hőmérséklet korlátozás (csak RDE100.1-nél)	0 = OFF (gyári érték) 1 = ON
P16	Padlófűtés hőmérsékletének max. korlátozása (csak RDE100.1-nél)	25...60 °C, 1°C lépésben vagy 77...140 °F, 1°F lépésben Gyári érték: 30 °C
P17	Ablak kontaktus jellege (csak RDE 100.1-nél)	0 = Alaphelyzetben nyitott kontaktus (gyári érték) 1 = Alaphelyzetben zárt kontaktus
P21	Kapacitív nyomógombok szkenelési rátája (csak RDE100.1) Figyelem: a rövidebb szkenelési ráta rövidebb elem élettartamot eredményez!	0.2 = 0.25 s 0.5 = 0.5 s 1.0 = 1.0 s (gyári érték) 1.5 = 1.5 s
P22	Gyári értékek visszaállítása	0 = OFF (gyári érték) 1 = Visszaállítás
P23	Szoftver verzió információ	Nincs lehetőség a változtatásra
P78	Vezérlési viselkedés	0 = Be/Ki, 1.0 K 1 = Be/Ki, 0.3 K 2 = TPI gyors 3 = TPI közepes 4 = TPI lassú (gyári érték)
P89	Bekapcsolás eltolás max	0, 0.5,...24 ó Gyári érték: 0 ó
P90	Korai lekapcsolás max	0, 0.5,...6 ó Gyári érték: 0 ó

HU

Akkumulátoros elektronikus berendezés ártalmatlanítása

HU



A berendezés ártalmatlanítás szempontjából az Európai Parlament és a Tanács 2012/19. irányelve értelmében elektronikus berendezésnek számít, és nem ártalmatlanítható kommunális hulladékként.

- A berendezést megfelelő módon ártalmatlanítsa.
- Vegye figyelembe a hatályos helyi jogszabályokat.
- A használt akkumulátorokat az e célra szolgáló gyűjtőállomásokon ártalmatlanítsa.

es Instrucciones de manejo







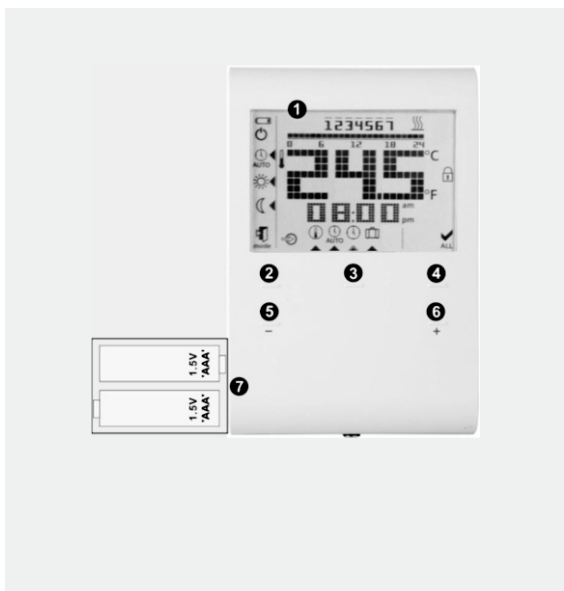





RDE100.. – el cronotermostato que le permite ajustar la temperatura ambiente ideal en cualquier momento que lo desee.

Existen patrones de conmutación disponibles que le permiten realizar ajustes a sus necesidades específicas.

ES



1. Display

	Indica que las pilas han de ser reemplazadas (solo la versión con alimentación por pilas)		Dígitos para la hora
	Protección Antihielo (calefacción) activa	am	Mañana: formato 12-horas
	Modo Programa horario	pm	Tarde: formato 12-horas
AUTO	Ver y ajustar Programa horario		Confirmación
	Modo Confort	°F	Temperatura ambiente en grados Fahrenheit
	Modo Economía	°C	Temperatura ambiente en grados Celsius
	Escape		Bloqueo de botones activado
	Entrada externa habilitada	245	Muestra temperatura ambiente, consignas, etc.
	Ajuste permanente de consigna		Calefacción ON
	Ajuste de fecha y hora		Día de la semana 1 = Lunes 7 = Domingo
	Ajuste modo Vacaciones		Barra horaria
			Temperatura ambiente actual

2. Cambiar modo operativo (mode)

3. Ajustes (set)

4. OK

5. Decrementar valor

6. Incrementar valor

7. Compartimento de pilas

¿Quiere ajustar la fecha y hora?

set	Proceda como sigue:
ok	<ul style="list-style-type: none"> • Presione set y seleccione 🕒
+	<ul style="list-style-type: none"> • Presione ok y la hora se pone intermitente a la espera de ajustes
-	
mode	<ul style="list-style-type: none"> • Presione + o - hasta ajustar la hora deseada • Presione ok para confirmar • El día de la semana se pone intermitente, presione + o - para seleccionar el día deseado • Presione ok para guardar el valor • Presione mode para salir del ajuste o espere un breve tiempo para salir automáticamente

¿Quiere bloquear los botones?

mode	<p>Mantenga presionado mode por al menos 7 segundos. Esto activa el bloqueo del teclado. Hacer lo mismo para desbloquear.</p> <p>La unidad trabaja con normalidad incluso si los botones están bloqueados, pero no es posible realizar algún cambio mientras los botones estén bloqueados.</p>
-------------	---

¿Está el ambiente demasiado caliente/frío?

+	Presione + o - para incrementar o decrementar la consigna en incrementos de 0.5 °C / 1 °F. Proceda como sigue:
-	
ok	<ul style="list-style-type: none"> • Presione + o - para ajustar la temperatura temporalmente. Este ajuste se deshace tan pronto como cambia de modo operativo. • Puede esperar por un tiempo para que se guarden los ajustes o presionar ok, set o mode para guardar inmediatamente dichos ajustes • Usted puede bloquear las consignas con los parámetros P06 y P08.
set	
mode	

¿Quiere usted cambiar el modo operativo?

mode El cronotermostato ofrece le modo Confort, modo Economía, el modo Programa horario. El cambio entre estos modos operativos se puede realizar manualmente presionando **mode**.

 **Modo Confort** es la selección permanente (24 h) de la consigna de Confort. Seleccionar este modo cuando quiera mantener constante sin ningún programa horario. Se utiliza durante los periodos de ocupación, por ejemplo.

Modo Economía es la selección permanente (24 h) de la consigna de Economía. Seleccionar este modo cuando quiera mantener constante sin ningún programa horario. Se utiliza durante los periodos de no ocupación, por ejemplo, por la noche.



Modo Programa horario es un tipo de operación donde los modos operativos (Confort, Economía) pueden cambiar de forma automática según un programa horario seleccionado.



Nota: Protección antihielo es una función siempre activa. Tan pronto como la temperatura ambiente cae por debajo de los 5 °C, la unidad automáticamente activa la salida de calefacción .

ES

¿Quiere ajustar las consignas de temperatura de forma permanente?

set	• Presione set y seleccione 
ok	• Presionar ok para confirmar
+	• Presionar mode para seleccionar el modo operativo, Confort o Economía
-	
mode	• Presione + o - para ajustar la consigna de forma permanente. • Presione ok para confirmar • Presione mode para salir o esperar un breve tiempo para salir automáticamente



Nota: Estas consignas permanentes se utilizar durante el modo de Programa horario.



Truco de ahorro energético sin sacrificar el confort

- Seleccionar el modo Programa horario durante el periodo de calefacción, y ajuste el programa horario acorde a sus hábitos normales en casa
- Seleccione el modo Economía o el modo Vacaciones durante largos periodos de no- ocupación y durante los periodos de verano

ES

¿Quiere seleccionar el modo Vacaciones?

set

ok

+

-

mode

En el modo Vacaciones, puede ajustar el cronotermostato a funcionar a una temperatura constante durante sus días de ausencia.

- Presione **set** y seleccione
- Presione **ok** para confirmar
- Presione **+** o **-** para ajustar la consigna de temperatura
- Presione **ok** para confirmar
- Luego presione **+** o **-** para ajustar el número de días que va ha estar fuera por vacaciones (Nota: 0 = Modo Vacaciones OFF)
- Presione **ok** para guardar los datos
- Una vez activado el modo Vacaciones, en la pantalla se muestran los días restantes para finalizar el modo Vacaciones.



Nota: Si presiona **mode** mientras está en modo Vacaciones, dicha función se desactiva y el icono desaparece de la pantalla.
Si los valores de las consignas de Confort y Economía están bloqueadas, le valor más bajo bloqueado es el valor de consigna del modo Vacaciones. Puede ajustar la consigna de temperatura desde 5 °C hasta el valor de consigna inferior bloqueado.

¿ Quiere programar su propio programa horario?

Opción 1: Programa horario con selección individual del día (P11=0)

ES

set
ok
+
-
mode

Puede seleccionar el modo Confort o Economía para cada intervalo de 15 minutos del día. La barra horaria de 0:00 a 24:00 horas le permite ajustar el modo operativo a través del día/s seleccionado/s.

Ejemplo:

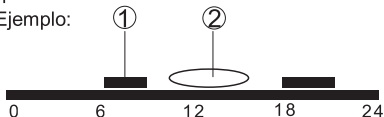

- ① Segmentos visibles: control en temperatura de Confort
- ② Segmentos invisibles: control en temperatura de Economía

Una vez guardados los ajustes, el cambio entre los modos operativos se lleva a cabo de forma automática cuando el Modo Programa Horario está habilitado.



Proceder como sigue:

- 1) Presione **set** y seleccione  AUTO.
- 2) Presione **ok** para confirmar.
- 3) Se muestra el programa horario para el día Lun(1)
- 4) Presione **+** o **-** para seleccionar el día, desde el Lun(1) a Dom(7).
- 5) Presione **ok** para confirmar la selección del día para iniciar la programación del horario.

Durante la programación de los pasos:

- 6) Presione **mode** para seleccionar el modo operativo, (Confort o Economía) **o**
- 7) Presione **+** o **-** para ajustar la consigna horaria en 15 minutos sobre el modo seleccionado.
- 8) Presione **ok** para guardar el programa anterior.
- 9) Repetir los pasos 4-8 para el resto de los días (si fuese necesario).
- 10) Presione **mode** o espere un breve tiempo para salir automáticamente.

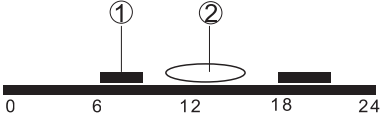
Opción 2: Programa horario con la misma selección para los 7 días de la semana (P11=1)

set ok + - mode	<p>Puede ajustar el programa de los 7 días al mismo tiempo. Ejemplo:</p>  <p>① Segmentos visibles: control en temperatura de Confort</p> <p>② Segmentos invisibles: control en temperatura de Economía</p> <p>Proceda como sigue:</p> <ol style="list-style-type: none">1) Ajuste el parámetro (P11=1). Por favor, referirse a la sección “¿Quiere cambiar los parámetros de ajuste?”2) Presione set y seleccione  AUTO.3) Presione ok para confirmar.4) Se muestra el programa horario para el periodo Lun (1) - Dom (7).5) Presione ok para iniciar la programación horaria. <div data-bbox="267 965 938 1172" style="border: 1px solid black; padding: 5px;"><p>Durante la programación de los pasos:</p><ol style="list-style-type: none">6) Presione mode para seleccionar el modo operativo, (Confort o Economía) o7) Presione + o - para ajustar la consigna horaria en 15 minutos sobre el modo seleccionado.</div> <ol style="list-style-type: none">8) Presione ok para guardar el programa anterior.9) Presione mode o espere un breve tiempo para salir automáticamente.
--	--

Opción 3: Programa horario con selección 5-2 diario-fin de semana (P11=2)

set
ok
+
-
mode

Puede ajustar el programa de lunes a viernes al mismo tiempo y sábado y domingo al mismo tiempo.
Ejemplo:

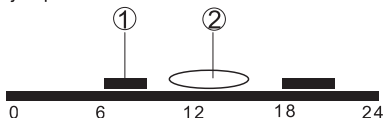

- ① Segmentos visibles: control en temperatura de Confort
- ② Segmentos invisibles: control en temperatura de Economía

Proceda como sigue:

- 1) Ajuste el parámetro (P11=1). Por favor, referirse a la sección “¿Quiere cambiar los parámetros de ajuste?”
- 2) Presione **set** y seleccione  AUTO.
- 3) Presione **ok** para confirmar.
- 4) Se muestra el programa horario para el periodo Lun(1) - Vie(5).
- 5) Presione **+** o **-** para seleccionar el periodo, Lun (1) - Vie(5) o Sab (6) - Dom (7).
- 6) Presione **ok** para confirma el periodo seleccionado para iniciar la programación horaria.

Durante la programación de los pasos:

- 7) Presione **mode** para seleccionar el modo operativo, (Confort o Economía) **o**
- 8) Presione **+** o **-** para ajustar la consigna horaria en 15 minutos sobre el modo seleccionado.

- 9) Presione **ok** para guardar el programa anterior
- 10) Repetir los pasos 5-9 para el otro periodo si fuese necesario, de otra manera
- 11) Presione **mode** o espere un breve tiempo para salir automáticamente.

Programa horario por defecto de fábrica 7-días

Valor por defecto	Día/s	Modo Confort	Modo Economía
	Lu (1) – Vi (5)	6:00 – 8:00 hr 17:00 – 22:00 hr	22:00 – 6:00 hr 8:00 – 17:00 hr
	Sa (6) – Do (7)	7:00 – 22:00 hr	22:00 – 7:00 hr

ES

¿Aparece este símbolo en la pantalla? (Solo la versión alimentada por pilas)

El símbolo  aparece en la pantalla cuando las baterías están bajas. Reemplace con 2 pilas alcalinas nuevas del tipo AAA. Proceda como sigue:

- Tenga preparada 2 pilas alcalinas nuevas tipo AAA
- Retirar el compartimento de las pilas, luego las pilas, e inserte las nuevas pilas y vuelva a colocar el compartimento de las pilas antes de 1,5 minutos.
- Deseche correctamente las pilas agotadas según la normativa medioambiental vigente.

¿Quiere cambiar los parámetros de ajuste?

+ - ok mode	<ul style="list-style-type: none">• Presione + y - simultáneamente durante 5 segundos• Liberar y entonces se muestra "P01" en la parte inferior• Presione + y - para seleccionar el parámetro que necesita ajustar• Presione ok para seleccionar el parámetro.• Presione + y - para ajustar el valor.• Presione ok para confirmar el valor. • Presione mode para salir sin guardar o espere un breve tiempo para volver a la pantalla normal
--	---

Listado de parámetros de ajuste

Parámetro N°	Descripción	Rango de ajuste (defecto)
P01	Formato de hora	1 = 24:00 horas (defecto) 2 = 12:00 AM/PM
P02	Selección de °C o °F	1 = °C (defecto) 2 = °F
P03	Pantalla temperatura estándar	1 = temperatura ambiente (defecto) 2 = consigna
P04	Calibración sonda ambiente	-3...3 °C salto 0.5 °C (-6...6 °F, salto 1 °F) Defecto: 0 °C
P06	Consigna bloqueo Confort	0 = OFF (defecto) 1 = ON → boqueo acorde al ajuste en consignas permanentes de temperatura
P08	Consigna bloqueo Economía	0 = OFF (defecto) 1 = ON → boqueo acorde al ajuste en consignas permanentes de temperatura
P09	Zumbador	0 = OFF 1 = ON (defecto)
P10	Mostrar icono protección antihielo	0 = OFF (defecto) 1 = ON
P11	Tipo de Programa Horario	0 = Días individuales (defecto) 1 = los 7 días 2 = 5/2 días
P12	Funcionamiento periódico bomba	0 = OFF (defecto) 1 = ON

P14	X1 Entrada externa (solo RDE100.1)	0 = Sin entrada 1 = Sonda externa 2 = Entrada digital
P15	Limitación temperatura (solo RDE100.1)	0 = OFF (defecto) 1 = ON
P16	Limitación máx temperatura para suelo radiante (solo RDE100.1)	25...60 °C, salto 1 °C o 77...140 °F, salto 1 °F Defecto: 30 °C
P17	Lógica contacto ventana (solo RDE100.1)	0 = Contacto normalmente abierto (defecto) 1 = Contacto normalmente cerrado
P21	Frecuencia de escaneo del teclado capacitivo (Solo RDE100.1) Nota: una frecuencia mayor de escaneo significa menor duración de la vida de la batería	0.2 = 0.25 s 0.5 = 0.5 s 1.0 = 1.0 s (defecto) 1.5 = 1.5 s
P22	Cargar ajuste de fábrica	0 = OFF (defecto) 1 = Cargar
P23	Información versión de software	Sin ajustes posibles
P78	Control comportamiento	0 = On/Off, 1.0K 1 = On/Off, 0.3K 2 = TPI rápido 3 = TPI medio 4 = TPI lento (defecto)
P89	Cambio hacia adelante máximo	0, 0.5,...24 h Defecto: 0 h
P90	Cierre anticipado máximo	0, 0.5,...6 h Defecto: 0 h

Eliminación de residuos de aparatos electrónicos con batería

ES



Este aparato es válido para su eliminación como residuo de aparato electrónico conforme a la Directiva europea 2012/19/UE y no se debe desechar como basura doméstica.

- Deseche el aparato a través de los canales previstos para tal fin.
- Tenga en cuenta la legislación local y vigente actualmente.
- Deseche las baterías antiguas en los puntos de recogida previstos para tal fin.

da **Betjeningsvejledning**

RDE100.. – Rumtermostaten, hvor det er muligt at indstille den perfekte rumtemperatur på de tidspunkter, du ønsker. Der findes flere forskellige omkoblingsmønstre, som kan indstilles efter dine særlige behov.

DA



1. Visning

 Indikerer at batterierne skal udskiftes (gælder kun for modeller med batterier)

 Frostbeskyttelse (varme) er aktiv

Auto Timer-drift

 AUTO
Vis og indstil
Automatisk
tidsprogram

 Komfortdrift

 Økonomidrift

 mode
Escape

 Ekstern indgang
aktiveret

 Permanent
setpunkt-indstilling

 Indstilling af ugedag
og tid

 Indstilling af feriedrift



Cifre, der angiver
tidspunkt

am
pm

Før middag:
12-timers format
Efter middag:
12-timers format



ALL

Bekræftelse

°F

Rumtemperatur i
Fahrenheit

°C

Rumtemperatur i
Celsius



Tastelås aktiveret

245

Visning af
rumtemperatur,
setpunkt osv.



Varme TIL

1 2 3 4 5 6 7

Ugedag
1 = Mandag,
7 = Søndag

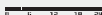

Tidsindstillingsbjælke



Aktuel
rumtemperatur

2. Skift driftsform (mode)

3. Indstil (set)

4. OK

5. Sænk værdi

6. Hæv værdi

7. Batteriholder

Vil du indstille tidspunkt og ugedag?

set	Gør følgende:
ok	<ul style="list-style-type: none">• Tryk på set og vælg .
+	<ul style="list-style-type: none">• Tryk på ok og tidspunktet blinker for indstilling.
-	<ul style="list-style-type: none">• Tryk på + eller - for at indstille tidspunktet.
mode	<ul style="list-style-type: none">• Tryk på ok for at bekræfte.• Ugedagen blinker. Tryk + eller - for at vælge den ønskede dag.• Tryk på ok for at gemme værdien.• Tryk på mode for at afslutte, eller vent på at programmet afslutter automatisk.

DA





Vil du låse tasterne?

mode	Tryk på mode og hold den nede i mindst 7 sekunder for at aktivere tastelåsen. Gentag for at låse op. Rumtermostaten fungerer normalt, når tasterne er låst, men det er ikke muligt at ændre noget, mens tasterne er låst.
-------------	---

Er der for varmt eller koldt i rummene?

+	Tryk på + eller - for at hæve eller sænke rumtemperatur-setpunktet i trin af 0,5 °C / 1 °F. Gør følgende:
-	
ok	<ul style="list-style-type: none">• Tryk på + eller - for at indstille setpunktet midlertidigt. Denne indstilling nulstilles så snart driftsformen skifter.• Tryk på ok, set eller mode for at gemme værdien, eller vent på at programmet afslutter automatisk.• For at låse setpunkterne bruges parametrene P06 og P08..
set	
mode	

Vil du ændre driftsform?

<p>mode</p> <p>DA</p> <p>!</p>	<p>Termostaten har Komfortdrift, Økonomidrift, Auto Timer-drift. Omkobling mellem driftsformerne kan foretages manuelt ved at man trykker på mode.</p> <p> Komfortdrift er det permanente (24 t) valg af Komfort-funktionen. Vælg denne driftsform for at opretholde en permanent komforttemperatur uden brug af tidsprogrammet. Funktionen bruges fx, når der er nogen til stede.</p> <p> Økonomidrift er det permanente (24 t) valg af Økonomi-funktionen. Vælg denne driftsform for at opretholde økonomitemperaturen permanent uden brug af tidsprogrammet. Den bruges, når der ikke er nogen til stede, fx om natten.</p> <p> AUTO Auto Timer-drift skifter driftsformerne (Komfort, Økonomi) automatisk i henhold til tidsprogrammets indstillinger.</p> <p>Bemærk: Frostbeskyttelse er en funktion, der altid er aktiv i baggrunden. Så snart rumtemperaturen falder til under 5 °C, starter rumtermostaten automatisk opvarmning .</p>
--------------------------------	---

Vil du indstille permanente temperatur-setpunkter?

<p>set ok + - mode</p>	<ul style="list-style-type: none">• Tryk på set og vælg .• Tryk på ok for at bekræfte.• Tryk på mode for at vælge en driftsform, Komfort eller Økonomi.• Tryk på + eller - for at indstille setpunktet permanent.• Tryk på ok for at bekræfte.• Tryk på mode for at afslutte, eller vent på at programmet afslutter automatisk.
--	---



Bemærk: Dette permanente setpunkt anvendes i Auto Timer-drift.





Tips til energibesparelse uden at det går ud over komforten

- Vælg Auto Timer-drift i varmeperioden og indstil tidsprogrammet i henhold til dine normale vaner derhjemme.
- Vælg Økonomidrift eller Feriedrift til længere perioder med fravær samt om sommeren.

DA

Vil du indstille dit Ferieprogram?

set	Brug Ferieprogrammet for at indstille termostaten til en konstant temperatur, når du ikke er hjemme.	
ok		
+	<ul style="list-style-type: none">• Tryk på set og vælg .• Tryk på ok for at bekræfte.• Tryk på + eller - for at indstille temperatur-setpunktet.• Tryk på ok for at bekræfte.• Tryk på + eller - for at indstille antallet af feriedage (Bemærk: 0 = Feriedrift FRA).• Tryk på ok for at gemme værdien.• Når Ferieprogrammet er aktiveret, vises de tilbageværende dage på skærmen.	
-		
mode		
!		<p>Bemærk: Hvis du trykker på mode, mens Ferieprogrammet er aktivt, afbrydes funktionen, og symbolet  forsvinder.</p> <p>Hvis setpunkterne for Komfort- og Økonomiværdierne begge er låst, vil den laveste låste setpunkt-værdi være Feriedriftens setpunkt-værdi. Man kan indstille setpunkt-temperaturen fra 5 °C og op til den laveste låste setpunkt-værdi.</p>

Vil du lave dine eget tidsprogram?

1. mulighed: Tidsprogram med individuelt valg af dage (P11=0)

set
ok
+
-
mode

Man kan vælge Komfortdrift eller Økonomidrift pr. 15. minut gennem hele dagen. Tidsbjælken kl. 0:00 – 24:00 giver dig mulighed for at indstille driftsformen for den/de valgte dag(e).

Eksempel:

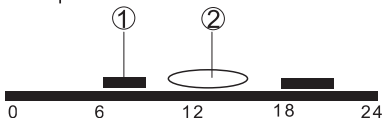

① Synlige bjælker: Styring til Komforttemperatur.

② Ingen bjælker: Styring til Økonomitemperatur.

Når Auto Timer-drift er aktiveret, sker omkobling mellem driftsformerne automatisk, efter at indstillingerne er gemt.



Gør følgende:

- 1) Tryk på **set** og vælg  AUTO.
- 2) Tryk på **ok** for at bekræfte valget.
- 3) Tidsprogram for ugedag Mon (1) vises.
- 4) Tryk på **+** eller **-** for at vælge dagen, fra Man (1) til Søn (7).
- 5) Tryk på **ok** for at bekræfte valget og starte tidsprogrammeringen.

Under programmeringen:

- 6) Tryk på **mode** for at vælge en driftsform (Komfort eller Økonomi), **eller**:
- 7) Tryk på **+** eller **-** for at sætte tidsindstillingen pr. 15. minut for den valgte driftsform.
- 8) Tryk på **ok** for at gemme tidsprogrammet.
- 9) Gentag trin 4-8 for alle de andre dage (hvis det ønskes); **eller**:
- 10) Tryk på **mode** eller vent på at programmet afslutter automatisk.

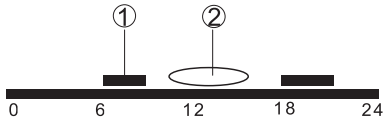
2. mulighed: Tidsprogram med det samme valg for hele ugen (P11=1)

set ok + - mode	<p>Man kan indstille tidsprogrammet for alle 7 dage på én gang: Eksempel:</p>
	
	<p>① Synlige bjælker: Styring til Komforttemperatur ② Ingen bjælker: Styring til Økonomitemperatur</p>
	<p>Gør følgende:</p>
	<ol style="list-style-type: none">1) Indstil parameteret (P11=1). Se venligst afsnittet "Vil du ændre parametre?".2) Tryk på set og vælg  AUTO.3) Tryk på ok for at bekræfte valget.4) Tidsprogram for perioden Man (1) – Søn (7) vises.5) Tryk på ok for at starte tidsprogrammeringen.
	<p>Under programmeringen:</p> <ol style="list-style-type: none">6) Tryk på mode for at vælge en driftsform (Komfort eller Økonomi), eller:7) Tryk på + eller - for at sætte tidsindstillingen pr. 15. minut for den valgte driftsform.
	<ol style="list-style-type: none">8) Tryk på ok for at gemme tidsprogrammet.9) Tryk på mode eller vent på at programmet afslutter automatisk.

3. mulighed: Tidsprogram med 5+2 dage (P11=2)

set
ok
+
-
mode

Man kan indstille tidsprogrammet for Mandag – Fredag på én gang og for Lørdag – Søndag på én gang.

Eksempel:

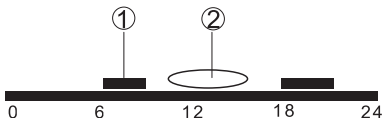

- ① Synlige bjælker: Styring til Komforttemperatur
② Ingen bjælker: Styring til Økonomitemperatur.

Gør følgende:

- 1) Indstil parameteret (P11=2). Se venligst afsnittet "Vil du ændre parametre?".
- 2) Tryk på **set** og vælg  AUTO.
- 3) Tryk på **ok** for at bekræfte valget.
- 4) Tidsprogram for perioden Man (1) – Fre (5) vises.
- 5) Tryk på **+** eller **-** for at vælge perioden, Man (1) – Fre (5) eller Lør (6) – Søn (7).
- 6) Tryk på **ok** for at bekræfte den valgte periode og starte tidsprogrammeringen.

Under programmeringen:

- 7) Tryk på **mode** for at vælge en driftsform (Komfort eller Økonomi), **eller:**
- 8) Tryk på **+** eller **-** for at sætte tidsindstillingen pr. 15. minut for den valgte driftsform.
- 9) Tryk på **ok** for at gemme tidsprogrammet.
- 10) Gentag om nødvendigt trinnene 5-9 for den anden periode; **eller:**
- 11) Tryk på **mode** eller vent på at programmet afslutter automatisk.

Fabriksindstillet tidsprogram for hele ugen

Fabriksindstillet værdi	Dag/e	Komfortdrift	Økonomidrift
	Ma (1) – Fr (5)	kl. 6:00 – 8:00 kl. 17:00 – 22:00	kl. 22:00 – 6:00 kl. 8:00 – 17:00
	Lø (6) – Sø (7)	kl. 7:00 – 22:00	kl. 22:00 – 7:00

Fremkommer symbolet på displayet? (Gælder kun for modeller med batteri)

DA

Symbolet  vises, når batterierne er flade. Udskift dem med 2 nye Alkaline-batterier type AAA.

Gør følgende:

- Find 2 nye Alkaline-batterier type AAA.
- Fjern batteriholderen og derefter batterierne. Indsæt de nye batterier og sæt batteriholderen tilbage inden for 1,5 minutter.
- Sørg for at de brugte batterier bortskaffes på korrekt vis i henhold til de miljømæssige krav.

Vil du ændre parametrene?

+ – ok mode	<p>Hvis du vil ændre reguleringsparametrene, skal du gøre følgende:</p> <ul style="list-style-type: none">• Tryk på + og – samtidig i 5 sekunder.• Slip dem igen, og parameter "P01" vises i nederste del.• Tryk på + eller – for at rulle til det parameter, der skal indstilles.• Tryk på ok for at vælge det parameter.• Tryk på + eller – for at indstille værdien.• Tryk på ok for at bekræfte den indstillede værdi.• Tryk på mode for at forlade parametrene uden at gemme, eller vent på at programmet afslutter automatisk.
--	---

Parameterliste

Parameter nr.	Beskrivelse	Indstillingsområde (fabriksindstilling)
P01	Tidsformat	1 = 24:00 timer (fabriksindstilling) 2 = 12:00 AM/PM
P02	Valg i °C eller °F	1 = °C (fabriksindstilling) 2 = °F
P03	Standard temperaturvisning	1 = rumtemperatur (fabriksindstilling) 2 = setpunkt
P04	Kalibrering af temperaturføler	-3...3 °C Trin 0,5 °C (-6...6 °F, trin 1 °F) Fabriksindstilling: 0 °C
P06	Lås for Komfort-setpunkt	0 = FRA (fabriksindstilling) 1 = TIL → låst i henhold til indstillingen i det permanente temperatur-setpunkt
P08	Lås for Økonomi-setpunkt	0 = FRA (fabriksindstilling) 1 = TIL → låst i henhold til indstillingen i det permanente temperatur-setpunkt
P09	Intern lyd giver	0 = FRA 1 = TIL (fabriksindstilling)
P10	Ikonet Vis frostbeskyttelse	0 = FRA (fabriksindstilling) 1 = TIL
P11	Type tidsprogram for Auto timer	0 = Individuelle dage (fabriksindstilling) 1 = Alle 7 dage 2 = 5/2 dage

P12	Periodisk pumpekørsel	0 = FRA (fabriksindstilling) 1 = TIL
P14	X1 Eksternt input (kun for RDE100.1)	0 = Intet input 1 = Ekstern føler 2 = Digitalt input
P15	Temperatur-begrænsning (gælder kun for RDE100.1)	0 = FRA (fabriksindstill.) 1 = TIL
P16	Maks.begrænsnings-temperatur for gulvvarme (gælder kun for RDE100.1)	25...60 °C, trin 1 °C eller 77...140 °F, trin 1 °F Fabriksindstilling: 30 °C
P17	Vindueskontakt-funktioner (gælder kun for RDE100.1)	0 = Normalt åben kontakt (fabriksindstilling) 1 = Normalt lukket kontakt
P21	Scanne-hastighed for de kapacitive taster (gælder kun for RDE100.1) Bemærk: En større scanning-hastighed betyder kortere batterilevetid)	0,2 = 0,25 s 0,5 = 0,5 s 1,0 = 1,0 s (fabriksindstilling) 1,5 = 1,5 s
P22	Gendan fabriksindstillinger	0 = FRA (fabriksindstilling) 1 = Gendan
P23	Information om software-version	Indstilling er ikke mulig
P78	Kontroladfærd	0 = Til/fra, 1.0 K 1 = Til/fra, 0.3 K 2 = TPI hurtig 3 = TPI mellem 4 = TPI langsom (fabriksindstilling)
P89	Maksimal tid inden avanceret start	0, 0.5,...24 timer Fabriksindstilling: 0 timer
P90	Maksimal tid inden avanceret nedlukning	0, 0.5,...6 timer Fabriksindstilling: 0 timer

DA

Bortskaffelse af brugt elektronisk udstyr med batteri

DA



I henhold til det europæiske direktiv 2012/19/EU anses udstyret for at være brugt elektronisk udstyr og må ikke bortskaffes som husholdningsaffald.











- Bortskaf udstyret ved anvendelse af de godkendte metoder.
- Overhold den nationale og aktuelt gældende lovgivning.
- Aflever brugte batterier på de dertil indrettede afleveringssteder.

tr Kullanım talimatları

RDE100.. – Bu termostat, istediğiniz zamanda ideal oda sıcaklığını ayarlamanıza olanak verir. Özel ihtiyaçlarınızı ayarlayabilmenize olanak veren bazı anaharlama modelleri bulunmaktadır.



1. Ekran

-  Pil deęiřtirme gstergesi (Yalnızca pil ile alıřan modellerde)
-  Donma Koruma aktif
-  Otomatik zamanlayıcı modu
Otomatik zamanlayıcı programı izlemek ve ayarlamak
-  Konfor modu
-  Ekonomi modu
-  ıkıř mode
-  Dıř giriř aktif
-  Kalıcı ayar sıcaklık
-  Gn ve tarih ayarlama
-  Tatil modu ayarları

 Zaman gstergesi

am

Saban: 12-saat formatı

pm

ğleden sonra: 12-saat formatı



ALL

Onay

°F

Fahrenheit birimiyle oda sıcaklıęı

°C

Celsius birimiyle oda sıcaklıęı



Tuř Kilidi Aktif

24.5

Oda sıcaklıęı, ayar sıcaklıęı vb. gstergesi



Isıtma aık

1 2 3 4 5 6 7

Haftanın gnleri
1 = Pazartesi. 7 = Pazar



Zaman izelgesi



Mevcut oda sıcaklıęı

2. alıřma modu deęiřtirme (mode)

3. Ayar (set)

4. OK

5. Deęer dřrme

6. Deęer arttırma

7. Pil yataęı

Zamanı ve günü ayarlamak ister misiniz?

set	Aşağıdaki adımları takip ediniz:
ok	• set tuşuna basın ve 🕒 tuşunu seçiniz.
+	• ok tuşuna basın ve zaman yanıp sönmeye başlayacaktır.
-	
mode	• + ve - tuşlarıyla zamanı ayarlayınız. • Onaylamak için ok tuşuna basınız • Haftanın günleri yanıp sönecektir, istenen günü + ve - tuşlarına basarak seçiniz. • Değerleri kaydetmek için ok tuşuna basınız. • Çıkmak için mode tuşuna basın ya da bir süre sonra otomatik olarak çıkacaktır.

TR







Tuşları kilitlemek ister misiniz?

mode	7 saniye boyunca mode tuşuna basılı tutunuz. Bu işlem tuş kilidini aktive eder. Aynısını tuş kilidini çözmek için de kullanınız. Tuşlar kilitliken cihaz normal çalışmasına devam eder fakat tuş kilidi çözülene kadar herhangi bir değişiklik yapılamaz
-------------	---

Odalarınız çok sıcak ya da soğuk mu?

+	Bu tuşlara basarak oda ayar sıcaklığını 0.5 °C / 1 °F derece arttırabilir ya da düşürebilirsiniz. Aşağıdaki adımları takip ediniz:
-	
ok	
set	
mode	• + yada - tuşlarına basarak geçici olarak ayar değerini ayarlayınız. Ayarlar çalışma modu değiştirildiğinde sıfırlanır. • Değeri kaydetmek için bir süre bekleyebilirsiniz ya da hemen kaydetmek için ok , set ya da mode tuşuna basabilirsiniz. • Sıcaklık ayar değerini kalıcı olarak, parametreleri ayarlayarak değiştirebilirsiniz. Parametre ayarlarından ayar değerini kilitleyebilirsiniz.

Çalışma modunu değiştirmek ister misiniz?

mode	<p>Termostat, konfor modunu ve ekonomi modunu. Manuel olarak mode tuşuna basılması ile çalışma modları arasında geçiş yapılır.</p> <p> Konfor modu Konfor ayar değerinin (20 °C) kalıcı seçimidir(24 h). Konfor sıcaklığını hiçbir zaman programına bağlı kalmaksızın devam ettirmek istediğinizde bu modu seçiniz. kullanım süresi boyunca Konfor modu kullanılır.</p> <p> Ekonomi Ekonomi ayar değerinin (16 °C) kalıcı seçimidir (24 h).Ekonomi sıcaklığını hiçbir zaman programına bağlı kalmaksızın devam ettirmek istediğinizde bu modu seçiniz. Kullanımda olmadığınız sürece Ekonomi modu kullanılır. Örneğin gece.</p> <p> Otomatik Zamanlayıcı modu Konfor, Ekonomi v.b. çalışma modlarının zamanlayıcı ayarlama ayarına göre otomatik olarak değiştirilebilmesidir.</p> <p>! NOT:</p> <p> Donma koruma arka planda devamlı çalışarak donmaya karşı koruma sağlar. Fonkiyon aktif olduğunda, ekranda  ikonu görülür. Donma koruma fonksiyonu oda sıcaklığı 5 °C ye düşerse, ısıtma çıkışını otomatik olarak aktive eder .</p>
-------------	--

Kalıcı sıcaklık ayarını değiştirmek ister misiniz?

set ok + - mode	<ul style="list-style-type: none">• set tuşuna basınız ve  sembolünü seçiniz.• Onaylamak için ok tuşuna basınız.• Bir çalışma modu seçmek için mode tuşuna basınız. (Konfor, Ekonomi)• Ayarları kalıcı olarak değiştirmek için + ya da - tuşuna basınız.• Onaylamak için ok tuşuna basınız.
--	--

!	<ul style="list-style-type: none"> • Çıkmak için mode tuşuna basınız, ya da otomatik olarak çıkması için bir süre bekleyiniz. <p>Not: Bu kalıcı ayar sıcaklığı, otomatik zaman modu süresince kullanılır.</p>
----------	--





Konfordan uzaklaşmadan Enerji tasarrufu yapmak

- Isıtma dönemi boyunca otomatik zamanlayıcı modu seçiniz ve evde normal alışkanlıklarınıza göre zaman programını ayarlayınız.
- Kullanım dışı dönemlerinizde ve yaz süresi boyunca ekonomi modu ya da tatil modunu seçiniz.

TR

Tatil modunu ayarlamak ister misiniz?

<p>set ok + - mode</p>	<p>Tatil modunda, bulunmadığınız süre boyunca termostatınızı sabit bir sıcaklık değerinde çalışmasını sağlayabilirsiniz.</p> <ul style="list-style-type: none"> • set tuşuna basın ve  ikonunu seçin. • Onaylamak için ok tuşuna basınız. • + ve - tuşlarına basarak ayar sıcaklığını ayarlayınız. • Onaylamak için ok tuşuna basınız. • Daha sonra tatilde olacağınız gün numaralarını + or - tuşlarına basarak ayarlayınız. (Not: 0 = Tatil modu OFF) • Değeri kaydetmek için ok tuşuna basınız. • Bir kez Tatil modu active edildiğinde kalan günler ekranda görülecektir. <p>! Not: Tatil modu çalışırken mode tuşuna basarsanız, özellik kapanacak ve  ikonu kaybolacaktır.</p> <p>Eğer konfor ve ekonomi ayar değerlerinin her ikisi de kilitliyse, kilitleli olan en düşük ayar değeri, Tatil modunun ayar değeri olarak seçilir. Ayar sıcaklık değerini 5 °C den en düşük kilitleli ayar değerine kadar seçebilirsiniz.</p>
---	---

Kendi zaman programınızı oluşturmak ister misiniz?

Seçenek 1: Farklı gün seçimi için zaman programı (P11=0)

set
ok
+
-
mode

Gün içerisinde her 15 dakika için Konfor ya da Ekonomi modunu seçebilirsiniz. Zaman Çizelgesi seçilen gün içinde saat 0:00 dan 24:00 e çalışma modlarını ayarlamanızı sağlar.

Örneğin:

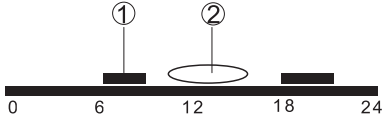

① Görünen bölüm: Konfor sıcaklığının kontrolü

② Görülmeyen bölüm: Ekonomi sıcaklığının kontrolü

Bir kez ayarlar kaydedildiğinde, Otomatik zaman Modu aktif olduğunda süre boyunca çalışma modları arasında geçiş otomatik olarak değişir.

Aşağıdaki adımları takip ediniz:

- 1) **set** tuşuna basınız ve  AUTO sembolünü seçiniz.
- 2) Onaylamak için **ok** tuşuna basınız.
- 3) Pazartesi (1) günü için zaman programı görülür.
- 4) Gün seçmek için **+** ve **-** tuşlarına basınız. Pazartesi den(1) Pazar a(7).
- 5) Seçilen tarihteki zaman programını onaylamak için **ok** tuşuna basınız.

Programlama adımları boyunca:

6) Bir çalışma modu seçmek için **mode** tuşuna basınız (Konfor, Ekonomi) ya da



7) Yukarıda seçilen mod için 15 dakikalık adımlarla **+** ve **-** tuşlarına basarak ayar yapınız.

8) Yukarıdaki programı onaylamak için ok tuşuna basınız.

9) Eğer isteniyorsa kalan diğer günler için 4-8 adımlarını tekrar ediniz. Aksi halde,

10) **mode** Tuşuna basınız ya da otomatik olarak çıkmak için bir süre bekleyiniz.

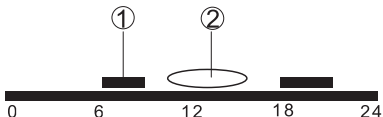
Seenek 2: Aynı gn seimi iin zaman programı (P11=1)

set ok + - mode	<p>Haftanın tm gnlerini aynı anda programlayabilirsiniz.</p> <p>rneęin:</p>  <p>① Grnen blm: Konfor sıcaklıęının kontrol</p> <p>② Grlmeyen blm: Ekonomi sıcaklıęının kontrol</p> <p>Ařaęıdaki adımları takip ediniz:</p> <ol style="list-style-type: none">1 (P11=1) parametresini ayarlayınız. Ltfen "Parametre ayarlarını deęiřtirmek ister misiniz?" blmn takip ediniz.2 set tuřuna basınız ve  semboln seiniz.3) Onaylamak iin ok tuřuna basınız.4) Pazartesi(1) den Pazar(7) a zaman programı grlr.5) Seilen zaman programını onaylamak iin ok tuřuna basınız. <p>Programlama adımları boyunca:</p> <ol style="list-style-type: none">6) Bir alıřma modu semek iin (Konfor, Ekonomi) mode tuřuna basınız ya da7) Yukarda seilen mod iin 15 dakikalık adımlarla + ve - tuřlarına basarak ayar yapınız.8) Yukarıdaki programı onaylamak iin ok tuřuna basınız.9) mode Tuřuna basınız ya da otomatik olarak ıkmak iin bir sre bekleyiniz.
--	---

Seçenek 3: 5-2 gün seçimi için Zaman programı(P11=2)

set
ok
+
-
mode

Tek seferde Pazartesi-Cuma günlerini ya da Cumartesi-Pazar günlerini ayarlayabilirsiniz.
Örneğin:

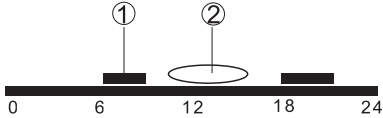

- ① Görünen bölüm Konfor sıcaklığı kontrolü
② Görülmeyen bölüm: Ekonomi sıcaklığı kontrolü

Aşağıdaki adımları takip ediniz:

1 (P11=2) parametresini ayarlayınız. Lütfen
"Parametre ayarlarını değiştirmek ister misiniz?"
bölümünü takip ediniz.

- 2) **set** tuşuna basınız ve  sembolünü seçiniz.
3) Onaylamak için **ok** tuşuna basınız.
4) Pazartesi(1) den Cuma(5) ya zaman programı görülür.
5) Pazartesi (1)-Cuma(5) ya da Cumartesi(6)-Pazar(7) dönemlerini seçmek için **+** ya da **-** tuşlarına basınız.
6) Seçilen zaman programını onaylamak için **ok** tuşuna basınız.

Programlama adımları boyunca:

- 7) Bir çalışma modu seçmek için (Konfor, Ekonomi) **mode** tuşuna basınız ya da
8) Yukarıda seçilen mod için 15 dakikalık adımlarla **+** ve **-** tuşlarına basarak ayar yapınız.

- 9) Yukarıdaki programı onaylamak için ok tuşuna basınız.
10) Eğer isteniyorsa kalan diğer günler için 5-9 adımlarını tekrar ediniz. Aksi halde,
11) **mode** Tuşuna basınız ya da otomatik olarak çıkmak için bir süre bekleyiniz.

7 Günlük Zaman Programı Fabrika Ayarları

Default değer	Gün	Konfor Modu	Ekonomi Modu
	P.tesi (1) – Cuma (5)	6:00 – 8:00 hr 17:00 – 22:00 hr	22:00 – 6:00 hr 8:00 – 17:00 hr
	Sa (6) – Su (7)	7:00 – 22:00 hr	22:00 – 7:00 hr

Ekranada sembolü mü görülüyor? Yalnızca pil ile çalışan versiyon için

Piller zayıfladığında  sembolü görülür. 2 yeni alkalin AAA tipi pil ile değiştiriniz. Aşağıdaki adımları takip ediniz:

- 2 yeni alkalin AAA tipi pil alınız.
- Pil tutucuyu ve ardından pilleri çıkarınız ve 1.5 dakika içerisinde yeni pilleri yerleştirerek pil tutucuyu kapatınız.
- Çevre gereksinimlerine uyum için, bitik pillerin doğru atıklarla atıldığına emin olunuz.

Parametreleri değiştirmek ister misiniz?

+ – ok mode	<ul style="list-style-type: none">• + ve – tuşlarına aynı anda 5 sn. Boyunca basınız.• Ve ekranda "P01" parametresi görülecektir.• + ve – tuşları ile ayarlamak istediğiniz parametreye ulaşır, ok butonu ile de seçebilirsiniz.• Gerekli parametreleri + ve – tuşları ile seçiniz ve ok e basarak onaylayınız• Ayarlanılan değerleri kaydetmeden çıkmak için mode tuşuna basınız. Değerleri kaydetmek ve ana ekrana dönmek için bir süre bekleyiniz.
--	--

Parameter list

Parameter no.	Açıklama	Ayar aralığı (default)
P01	Zaman formatı	1 = 24:00 (default) 2 = 12:00 AM/PM
P02	°C yada °F seçimi	1 = °C (default) 2 = °F
P03	Standard sıcaklık Ekranı	1 = oda sıcaklığı (default) 2 = Ayar sıcaklığı
P04	TSıcaklık sensörü kalibrasyonu	-3...3 °C Adım 0.5 °C (-6...6 °F, Adım 1 °F) Default: 0 °C
P06	Konfor ayar sıcaklık kilidi	0 = OFF (default) 1 = ON → ayarlanan sıcaklığa göre kilitli
P08	Ekonomi ayar sıcaklığı	0 = OFF (default) 1 = ON → ayarlanan sıcaklığa göre kilitli
P09	İkaz sesi	0 = OFF 1 = ON (default)
P10	Donma Koruma Fonksiyonu ikonunun ekranda görülmesi	0 = OFF (default) 1 = ON
P11	Otomatik zamanlayıcı için zaman program tipi	0 = individual Days (default) 1 = Tüm Hafta günleri 2 = Hafta içi/Hafta Sonu
P12	Periyodik pompa çalışması	0 = OFF (default) 1 = ON

P14	X1 harici giriři (sadece RDE100.1 için)	0 = nput yok 1 = Dış sensör 2 = Digital Input
P15	Sıcaklık kısıtlama (sadece RDE100.1 için)	0 = OFF (default) 1 = ON
P16	Yerden ısıtmada max sıcaklık sınırlaması (sadece RDE100.1 için)	25...60 °C, adım 1 °C or 77...140 °F, adım 1 °F Default: 30 °C
P17	Kapı Konağı özelliği (yalnızca RDE 100.1 için)	0 = Normalde açık kontak (default) 1 = Normalde kapalı kontak
P21	Kapasitif butonların algı tarama sıklığı (sadece RDE100.1 için) NOT: Daha sık algı taraması, daha kısa pil ömrüne neden olacaktır.	0.2 = 0.25 s 0.5 = 0.5 s 1.0 = 1.0 s (default) 1.5 = 1.5 s
P22	Fabrika ayarlara geri dön	0 = OFF (default) 1 =yükle
P23	Yazılım versiyon bilgisi	Ayar mümkün değildir.
P78	Kontrol davranışı	0 = On/Off, 1.0K 1 = On/Off, 0.3K 2 = TPI hızlı 3 = TPI orta 4 = TPI yavaş (default)
P89	Erken başlama süresi	0, 0.5,...24 h Default: 0 h
P90	Erken kapanma maksimum	0, 0.5,...6 h Default: 0 h

TR

Pilli eski elektronik cihazların tasfiye edilmesi

TR



Cihaz, 2012/19/AT sayılı Avrupa Birliđi direktifi uyarınca eski elektronik cihaz olarak tasfiye edilmeli, evsel atıklarla birlikte tasfiye edilmemelidir.

- Cihazı dođru tasfiye kanalları ile tasfiye edin.
- Yerel ve g¼ncel yasaları dikkate alın.
- Kullanılmıř pilleri ¼ng¼r¼len toplama noktalarına g¼ndererek tasfiye edin.

nl Bedieningshandleiding

RDE100.. – De ruimtetemperatuurregelaar voor de juiste temperatuur op de juiste tijd. Er kan uit verschillende gebruikerspatronen worden gekozen, de patronen kunnen naar ieders wensen worden aangepast.



1. Display

	Batterijen vervangen (uitsluitend voor types met batterijvoeding)		Tijdstip aanduiding
	Vorstbeveiligings-bedrijf is actief	am	Voormiddag: 12-uur formaat
	Automatisch bedrijf is actief	pm	Namiddag: 12-uur formaat
			Bevestiging
	Continu Comfortbedrijf	ALL	
	Continu Verlagingsbedrijf	°F	Ruimtetemperatuur in graden Fahrenheit
	Menu verlaten	°C	Ruimtetemperatuur in graden Celsius
			Toetsenblokkering aan
	Externe ingang geactiveerd	245	Weergave ruimtetemperatuur
	Temperatuur instellingen		Verwarming AAN
	Dag en tijd instellingen		Weekdag 1 = Maandag 7 = Zondag
	Afwezigheids/vakantie bedrijf instellingen		Tijds kader
			Huidige ruimtetemperatuur

2. Toets voor wijziging bedrijfswijze (mode)

3. Keuzetoets voor instellingen (SET)

4. Bevestigingstoets (OK)

5. Toets om waarde te verlagen (-)

6. Toets om waarde te verhogen (+)

7. Batterijhouder

Tijd en datum invoeren

toets	Volg volgende instructies:
set	• Druk op keuzetoets en selecteer 🕒
ok	• Druk op ok en tijd begint te knipperen
+/-	• Druk op + of - en stel tijd correct in
ok	• Druk op ok om te bevestigen
	• De weekdag knippert, druk op + of - om dag van de week in te stellen
mode	• Druk op ok om waarde te bewaren
	• Druk op mode om menu te verlaten of wacht tot het menu automatisch wordt verlaten.

NL





Toetsenvergrendeling activeren

mode	Toets mode voor tenminste 7 seconden ingedrukt houden om toetsenblokkering in te schakelen, herhaal de handeling om te ontgrendelen. De thermostaat werkt normaal tijdens een toetsenblokkering maar wijzigingen zijn niet meer mogelijk.
-------------	--

Temperatuurniveau wijzigen

+	Druk toets + of - in om gewenste temperatuur te verhogen of verlagen met stappen van 0.5 °C / 1 °F.
-	
ok	Volg volgende instructies:
set	• Druk op + of - om temperatuur tijdelijk te wijzigen.
mode	De wijziging wordt ongedaan gemaakt zodra de bedrijfswijze verandert.
	• Druk op ok , set of mode om wijziging tijdelijk op te slaan of wacht tot het menu automatisch wordt verlaten.
	• Om deze instellingen te vergrendelen, stel parameters P06 en P08 in.

Bedrijfswijze wijzigen

<p>mode</p> <p>!</p>	<p>De volgende bedrijfswijzen zijn beschikbaar: Comfort, Verlagsings-, Auto- en Vorstbeveiligingsbedrijf. Omschakeling tussen verschillende bedrijfswijzen kan handmatig door mode in te drukken.</p> <p> Comfort bedrijf, de comforttemperatuur wordt continu (24 h) behouden zonder onderbreking.</p> <p> Verlagsings bedrijf, de verlagingstemperatuur wordt continu (24 h) behouden zonder onderbreking.</p> <p> AUTO Automatisch bedrijf, de bedrijfswijzen Comfort en Verlaging wijzigen automatisch volgens de ingestelde schakeltijden.</p> <p> Vorstbeveiliging bedrijf de vorstbeveiligings-temperatuur wordt continu (24 h) behouden zonder onderbreking. Deze functie wordt actief als de ruimtetemperatuur onder de 5 °C komt. De thermostaat activeert de verwarming en het icoon  verschijnt in het scherm.</p> <p>Opmerking: Het vorstbeschermingsicoon kan worden uitgeschakeld via parameterinstelling P10.</p>
------------------------------------	---

Permanente temperatuurinstelling wijzigen



<p>set</p> <p>ok</p> <p>+</p> <p>-</p> <p>mode</p> <p>!</p>	<ul style="list-style-type: none">• Druk op set en selecteer • Druk op ok om te bevestigen.• Druk op mode om bedrijfswijze comfort of verlaging te selecteren.• Druk op + of - om temperatuur permanent te wijzigen.• Druk op ok om te bevestigen.• Druk op mode om het menu te verlaten of wacht tot het menu automatisch wordt verlaten. <p>Opmerking: Deze instellingen zijn van toepassing tijdens het AUTO bedrijf.</p>
---	---

Energiebesparing-tips

- Selecteer Auto bedrijf tijdens het verwarmingsseizoen, en stel het automatisch bedrijf in volgens uw gewoonten en aan- en afwezigheid.
- Selecteer verlaging- of vakantiebedrijf voor lange perioden van afwezigheid of tijdens de zomerperiode.

Vakantieperiode of afwezigheid invoeren

NL

set	Gebruik vakantiebedrijf om de thermostaat in te stellen op een constante t° tijdens uw afwezigheid.
ok	
+	<ul style="list-style-type: none">• Druk op set en selecteer 
-	<ul style="list-style-type: none">• Druk op ok om te bevestigen.
mode	<ul style="list-style-type: none">• Druk op + of - om gewenste t° in te stellen.• Druk op ok om te bevestigen.• Druk op + of - om het aantal vakantiedagen in te geven (Opmerking : 0 = Vakantiebedrijf UIT).• Druk op ok om instellingen te bewaren.• Indien vakantiebedrijf actief is, worden de resterende dagen in het scherm weergegeven.
!	<p>Opmerking: Indien u op de toets mode drukt tijdens vakantiebedrijf, wordt de functie vakantie geannuleerd en het symbool  verdwijnt uit het scherm. Indien de comforttemperatuur en verlaging- temperatuur werden vergrendeld, dan wordt de laagste ingestelde temperatuur als referentietemperatuur gebruikt. U kunt de temperatuur instellen tussen 5 °C en de laagste ingestelde temperatuur.</p>

Schakeltijden instellen

Optie 1: Schakelklok met weekprogramma (P11=0)

set
ok
+
-
mode

U kunt comfort bedrijf of verlagingsbedrijf instellen met intervallen van 15 minuten tijdens de dagen van de week. De 0:00 tot 24:00 u tijdsaanduiding visualiseert uw instellingen.

Voorbeeld:

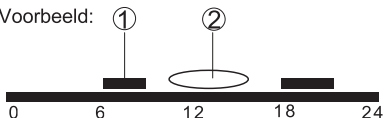

① Zichtbare staaf: comforttemperatuur actief

② Onzichtbare staaf: verlagingsstemperatuur actief

Nadat de instellingen zijn opgeslagen en de thermostaat in automatisch bedrijf is geschakeld, gaat het apparaat automatisch van comfort naar verlagings schakelen en visa versa.

Volg volgende instructies:

- 1) Druk op **set** en selecteer  AUTO.
- 2) Druk op **ok** om te bevestigen.
- 3) Periode voor Maandag (1) wordt afgebeeld.
- 4) Druk op **+** of **-** om dag te selecteren, van maandag (1) tot zondag (7).
- 5) Druk op **ok** om selectie te bevestigen.

Volgende stap tijdens het programmeren:

- 6) Druk op **mode** om een bedrijfswijze te selecteren (comfort of verlagings. of
- 7) Druk op **+** of **-** om aan en uit tijden in te stellen met stappen van 15 minuten.
- 8) Druk op **ok** om schakeltijden op te slaan.
- 9) Herhaal stappen 4 tot 8 voor alle overige dagen of
- 10) Druk op **mode** of wacht tot het menu automatisch wordt verlaten.

Optie 2: Schakelklok met dagprogramma (P11=1)

set
ok
+
-
mode

U stelt de schakeltijden voor alle 7 dagen samen.
Voorbeeld:

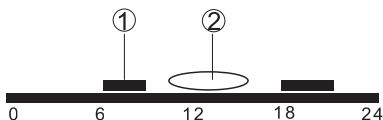

- ① Zichbare staaf: comforttemperatuur actief
② Onzichtbare staaf: verlagingstemperatuur actief

Volg volgende instructies:

- 1) Stel parameter (P11=1) in. Zie “**Instellen parameters**”.
- 2) Druk op **set** en selecteer  AUTO.
- 3) Druk op **ok** om te bevestigen.
- 4) Periode van maandag (1) tot zondag (7) wordt afgebeeld.
- 5) Druk op **ok** om selectie te bevestigen.

Volgende stap tijdens het programmeren:

- 6) Druk op **mode** om een bedrijfswijze te selecteren (comfort of verlaging) of
- 7) Druk op **+** of **-** om aan en uit tijden in te stellen met stappen van 15 minuten.
- 8) Druk op **ok** om schakeltijden op te slaan.
- 9) Druk op **mode** of wacht tot het menu automatisch wordt verlaten.

Optie 3: Schakeltijd met 5/2 dagen programma (P11=2)

set
ok
+
-
mode

U kunt de schakeltijden van maandag tot vrijdag en van zaterdag tot zondag instellen.

Voorbeeld:

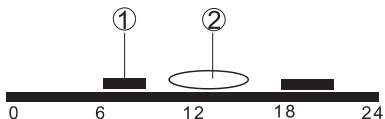

① Zichbare staaf: comforttemperatuur actief

② Onzichtbare staaf: verlagingstemperatuur actief

Volg volgende instructies:

1) Stel parameter (P11=2) in. Zie "**Instellen parameters**".

2) Druk op **set** en selecteer  AUTO.

3) Druk op **ok** om te bevestigen.

4) Periode van maandag (1) tot vrijdag (5) wordt afgebeeld.

5) Druk op **+** of **-** selecteer periode, maandag (1) - vrijdag(5) of zaterdag (6) - zondag(7).

6) Druk op **ok** om gekozen periode te bevestigen en stel de tijdsblokken in.

Volgende stap tijdens het programmeren:

7) Druk op **mode** om een bedrijfswijze te selecteren (comfort of verlaging) **of**

8) Druk op **+** of **-** om aan en uit tijden in te stellen met stappen van 15 minuten.

9) Druk op **ok** om schakeltijden op te slaan.

10) Herhaal stappen 5 tot 9 voor de overige periode of

11) Druk op **mode** of wacht tot het menu automatisch wordt verlaten.

Fabrieksinstellingen weekprogramma

Standaard waarde	Dag/en	Comfort bedrijf	Verlaging bedrijf
	ma (1) – vr (5)	6:00 – 8:00 17:00 – 22:00	22:00 – 6:00 8:00 – 17:00
	za (6) – zo (7)	7:00 – 22:00	22:00 – 7:00

Wordt symbool weergegeven in het display? (uitsluitend voor types met batterijvoeding)

NL

Als symbool  wordt weergegeven, moet u de batterijen vervangen. Vervang batterijen met 2 nieuwe alkaline batterijen type AAA, 1,5V:

- Neem 2 nieuwe alkaline batterijen type AAA
- Verwijder batterijhouder vervolgens de batterijen, plaats de nieuwe batterijen en plaats batterijhouder terug.
- Verwijder de batterijen volgens de geldende voorschriften.

Instellen parameters

+ - ok mode	<p>Voor het wijzigen van parameters, volg volgende instructies:</p> <ul style="list-style-type: none">• Druk op + en - gelijktijdig gedurende 5 seconden.• Los de toetsen en parameter "P01" verschijnt in het display.• Druk toets + of - om te scrollen naar de parameter(s) die u wenst te wijzigen.• Druk op ok om parameter te selecteren• Druk op + of - om waarde aan te passen.• Druk op ok om de gecorrigeerde waarde op te slaan.• Druk op mode om het menu parameters te verlaten zonder op te slaan of wacht tot het menu automatisch wordt verlaten.
--	--

Parameterlijst

Parameter n°	Beschrijving	Instelbereik (standaard)
P01	Tijdsformaat	1 = 24:00 uur (standaard) 2 = 12:00 AM/PM
P02	Temperatuurselectie °C of °F	1 = °C (standaard) 2 = °F
P03	Temperatuur-aanduiding	1 = ruimtetemperatuur (standaard) 2 = temperatuurinstelling
P04	Temperatuurvoeler calibratie	-3...3 °C Stappen van 0.5 °C (-6...6 °F, stappen van 1 °F) standaard: 0 °C
P06	Vergrendeling comforttemperatuur	0 = OFF (standaard) 1 = ON → Vergrendeld (instelling permanente temperatuurinstelling)
P08	Vergrendeling verlagingstemperatuur	0 = OFF (standaard) 1 = ON → Vergrendeld (instelling permanente temperatuurinstelling)
P09	Zoemer	0 = OFF 1 = ON (standaard)
P10	Icoon vorstbeveiliging in het display	0 = OFF (standaard) 1 = ON
P11	Selectie regime	0 = weekprogramma (standaard) 1 = dagprogramma 2 = 5/2 dagen
P12	Periodieke pomp kick	0 = OFF (standaard) 1 = ON

P14	X1 Externe ingang (uitsluitend RDE100.1)	0 = Geen ingang 1 = Externe voeler 2 = Digitale Ingang
P15	Temperatuur limiet (uitsluitend RDE100.1)	0 = OFF (standaard) 1 = ON
P16	Max limiet temperatuur voor vloerverwarming (uitsluitend RDE100.1)	25...60 °C, stappen 1 °C of 77...140 °F, stappen 1 °F Standaard: 30 °C
P17	Venstercontact (uitsluitend RDE 100.1)	0 = Normaal open Contact (standaard) 1 = Normaal Gesloten Contact
P21	Toetsen scanning (uitsluitend RDE100.1) Opmerking: een hogere scanning rate betekent een kortere levensduur van de batterijen.	0.5 = 0.5 s 1.0 = 1.0 s (standaard) 1.5 = 1.5 s 2.0 = 2.0 s 2.5 = 2.5 s 3.0 = 3.0 s 3.5 = 3.5 s 4.0 = 4.0 s 4.5 = 4.5 s 5.0 = 5.0 s
P22	Terug naar fabrieksinstellingen	0 = OFF (standaard) 1 = terug fabrieksinstelling
P23	Software versie informatie	Geen wijzigingen mogelijk
P78	Regelgedrag	0 = Aan/Uit, 1.0K 1 = Aan/Uit, 0.3K 2 = TPI snel 3 = TPI middel 4 = TPI langzaam (standaard)
P89	Aanwarmtijd max	0, 0.5,...24 h standaard: 0 h
P90	Vervroegd uit max	0, 0.5,...6 h standaard: 0 h

NL

Afvoer afgedankte elektronische apparatuur met batterij

NL



Het toestel geldt voor de afvalverwerking als afgedankte elektronische apparatuur conform de Europese richtlijn 2012/19/EU en mag niet via het huishoudelijke afval worden afgevoerd.

- Verwijder het toestel via de daartoe bestemde kanalen.
- Let op de lokale en momenteel geldende voorschriften.
- Breng afgedankte accu's naar de daartoe bestemde verzamelpunten.

zh 操作手册

RDE100.. 房间温控器能够根据需要设定室内温度，还提供了几种定时设置以满足不同需求。



ZH

1. 屏幕显示

	需要更换电池 (仅限电池供电版本)		时间
	防冻(供热)模式开启	am	上午(12小时制)
	自动定时模式	pm	下午(12小时制)
AUTO	查看并进行定时设置		确定
	舒适模式	ALL	
	节能模式	°F	室内华氏温度(°F)
	退出	°C	室内摄氏温度(°C)
mode			按钮锁定功能启用
	支持外部输入	24.5	室内温度、设定值等
	长期设定值设置		供热开启
	时间和日期设置	星期	
	假日模式设置	1 2 3 4 5 6 7	1 = 星期一 7 = 星期日
			时间条
			当前室内温度

2. 更改运行模式

3. 设置

4. 确定

5. 调低数值

6. 调高数值

7. 电池座

您是否希望进行时间和日期设置？

设置 确定 + - 模式	操作步骤如下： <ul style="list-style-type: none">• 按设置并选定 • 按确定，时间开始闪烁以供设定• 按 + 或 - 调整时间• 按确定进行确认• 星期开始闪烁，按 + 或 - 可以进行日期设置• 按确定保存设置• 按模式退出或等待程序自动退出
---	--

ZH

您是否希望锁定按钮？





模式	按住 模式 按钮至少 7 秒钟，可以锁定按钮。再次按住 模式 按钮至少 7 秒钟，可以解锁按钮。 按钮锁定时温控器正常运行，但是不能进行更改。
-----------	--

您的室内温度是否过高/过低？

<p>+</p> <p>-</p> <p>确定 设置 模式</p>	<p>在舒适模式下按 + 或 - 键，能以 0.5 °C / 1 °F 为步长升高或降低室内温度设定值。操作步骤如下：</p> <ul style="list-style-type: none">按 + 或 - 可以临时更改设定值 设定值临时更改将在运行模式更改后即刻重置按确定、设置或模式来保存设置或等待程序自动退出通过参数 P06 和 P08 可锁定设定值
--	---

ZH

您是否希望更改运行模式？

<p>模式</p> <p>!</p>	<p>RDE100.. 温控器提供舒适模式、节能模式和自动模式按模式可以手动切换运行模式。</p> <p> 舒适模式是将运行模式长期（24 小时）选择为舒适。选择该模式可长期保持舒适的室内温度，无需定时设置。舒适模式适用于室内有人的时段（如日间）。</p> <p> 节能模式是将运行模式长期（24 小时）选择为节能。选择该模式可长期保持节能的室内温度，无需定时设置。节能模式适用于室内无人的时段（如夜间）。</p> <p> AUTO 在自动定时模式下，运行模式（舒适模式和节能模式）能够基于定时设置自动切换。</p> <p>注意： 防冻模式一直在后台开启。当室内温度降至 5 °C 以下时，温控器自动启动供热 。</p>
----------------------------------	---

您是否希望长期设定温度设定值？



<p>设置 确定 + - 模式</p> <p>!</p>	<ul style="list-style-type: none">按设置并选定 按确定进行确认按模式选择运行模式（舒适模式或节能模式）按 + 或 - 可以长期更改设定值按确定进行确认按模式退出或等待程序自动退出 <p>注意：长期设定值适用于自动定时模式</p>
--	---

ZH

在不影响舒适度的前提下进行节能

- 在供暖季选择自动定时模式，并根据起居习惯进行定时设置
- 在较长的室内无人时段和夏季选择节能模式或假日模式

您是否希望将温控器设置为假日模式？

<p>设置 确定 + - 模式</p> <p>!</p>	<p>在室内无人的时段，将温控器设置为假日模式以持续保持特定的室内温度。</p> <ul style="list-style-type: none">按设置并选定 按确定进行确认按 + 或 - 更改温度设定值按确定进行确认按 + 或 - 调整假日天数（注：0 = 假日模式禁用）按确定保存设置当假日模式启用时，温控器上显示剩余的假日天数 <p>注意：如果在温控器处于假日模式时按模式键，则假日模式被禁用，屏幕不再显示图标 。</p> <p>如果舒适模式和节能模式设定值均锁定，则锁定的最低设定值为假日模式的设定值。可对假日模式设定值进行更改，范围为 5 °C 至锁定的最低设定值。</p>
--	--

您是否希望进行定时设置？

方案 1：可对每天分别设定的定时设置 (P11=0)

设置
确定
+
-
模式

能以 15 分钟为步长为一天中的各时段选择舒适模式或节能模式。通过范围为 0:00 至 24:00 的时间条，可以为选定的日期分时段设定运行模式。

示例：

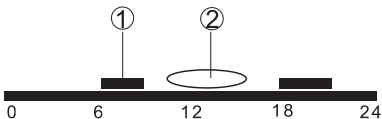

① 显示的时间条：舒适室温控制

② 隐藏的时间条：节能室温控制

自动定时模式启用时，定时设置保存后温控器可以在各个运行模式之间自动切换。

操作步骤如下：

- 1) 按**设置**并选定  AUTO.
- 2) 按**确定**进行确认
- 3) 星期一 (1) 定时设置可用
- 4) 按 **+** 或 **-** 选择日期（星期一 (1) 至星期日(7)）
- 5) 按**确定**确认选择并启动时间编程

在时间编程过程中：

- 6) 按**模式**选择运行模式（舒适模式或节能模式），
或者
- 7) 按 **+** 或 **-** 以 15 分钟为步长为所选模式设定时间
- 8) 按**确定**保存定时设置
- 9) 重复步骤 4-8 进行其它日期的定时设置（如果需要），
或者
- 10) 按**模式**退出或等待程序自动退出

方案 2：可对整个星期统一设定的定时设置 (P11=1)

设置
确定
+
-
模式

您可对整个星期（7 天）进行定时设置，使定时设置应用到每一天。

示例：

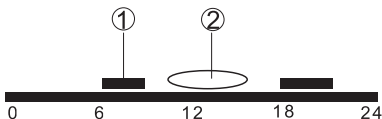

① 显示的时间条：舒适室温控制

② 隐藏的时间条：节能室温控制

操作步骤如下：

- 1) 设置参数 (P11=1),请参见“您是否希望更改参数？”章节。
- 2) 按**设置**并选定 
- 3) 按**确定**进行确认
- 4) 星期一 (1) 至星期日 (7) 定时设置可用
- 5) 按**确定**启动时间编程。

在时间编程过程中：

- 6) 按**模式**选择运行模式（舒适模式或节能模式），
或者
- 7) 按 **+** 或 **-** 以 15 分钟为步长为所选模式设定时间
- 8) 按**确定**保存定时设置
- 9) 按**模式**退出或等待程序自动退出

ZH

方案 3：可对工作日和周末 (5-2) 分别设定的定时设置 (P11=2)

设置
确定
+
-
模式

您可以对工作日（星期一至星期五）和周末（星期六至星期日）分别进行定时设置。

示例：

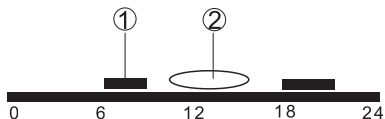

① 显示的时间条：舒适室温控制

② 隐藏的时间条：节能室温控制

操作步骤如下：

- 1) 设置参数 (P11=2),请参见“您是否希望更改参数？”章节。
- 2) 按**设置**并选定 .
- 3) 按**确定**进行确认
- 4) 星期一 (1) 至星期五 (5) 定时设置可用
- 5) 按 **+** 或 **-** 选择定时设置日期：星期一 (1) 至星期五 (5) 或星期六 (6) 至星期日 (7)
- 6) 按**确定**确认选择并启动时间编程

在时间编程过程中：

- 7) 按**模式**选择运行模式（舒适模式或节能模式），
或者
- 8) 按 **+** 或 **-** 以 15 分钟为步长为所选模式设定时间
- 9) 按**确定**保存定时设置
- 10) 重复步骤 5-9 进行其它日期的定时设置（如果需要），**或者**
- 11) 按**模式**退出或等待程序自动退出

ZH

定时设置的出厂默认设置 (5-2)

默认设置	日期	舒适模式	节能模式
	星期一 (1) - 星期五 (5)	时段: 6:00 - 8:00 时段: 17:00 - 22:00	时段: 22:00 - 6:00 时段: 8:00 - 17:00
	星期六 (6) - 星期日 (7)	时段: 7:00 - 22:00	时段: 22:00 - 7:00

屏幕上是否显示图标 ?

ZH

(仅限电池供电的机型)

电池电量低时屏幕显示图标 。需更换 2 节 AAA 型号碱性电池。操作步骤如下:

- 准备好 2 节 AAA 型号碱性电池。
- 卸除电池座并取出旧电池。于 1.5 分钟内插入新电池并将电池座安装到温控器上。
- 确保按照环保要求妥善处置废电池。

您是否希望更改参数?

+
-
确定
模式

如需更改控制参数, 请执行以下操作:

- 同时按下 + 和 - 5 秒钟
- 放开按钮后屏幕下方显示参数 P01
- 按下 + 和 - 滚动参数, 直至显示需要更改的参数
- 按**确定**选定需要更改的参数
- 按 + 或 - 更改数值
- 按**确定**确认数值更改
- 按**模式**放弃参数修改并退出, 或等待程序自动退出

参数列表

参数	说明	设定范围（默认）
P01	时间格式	1 = 24:00 小时制（默认） 2 = 12:00 小时制（上午/下午）
P02	°C 或 °F 的选择	1 = °C（默认） 2 = °F
P03	标准温度显示	1 = 室内温度（默认） 2 = 设定值
P04	温度传感器校验	-3...3 °C，步长 0.5 °C (-6...6 °F，步长 1 °F) 默认值：0 °C
P06	舒适设定值锁定	0 = OFF（默认） 1 = ON → 锁定，视长期温度设定值设置而定
P08	节能设定值锁定	0 = OFF（默认） 1 = ON → 锁定，视长期温度设定值设置而定
P09	蜂鸣器	0 = OFF 1 = ON（默认）
P10	显示防冻图标	0 = OFF（默认） 1 = ON
P11	自动定时模式的定时设置类型	0 = 每天分别设定（默认） 1 = 整个星期统一设定 2 = 工作日和周末分别设定
P12	泵的周期性运行	0 = OFF（默认） 1 = ON

P14	X1 外部输入 (仅限 RDE100.1)	0 = 无输入 1 = 外部传感器输入 2 = 数字输入
P15	温度限值 (仅限 RDE100.1)	0 = OFF (默认) 1 = ON
P16	地热垫温度限值 (仅限 RDE100.1)	25...60 °C , 步长 1 °C (77...140 °F, 步长 1 °F) 默认值: 30 °C
P17	窗磁功能 (仅限 RDE100.1)	0 = 常开 (默认) 1 = 常闭
P21	电容按钮的扫描速度 (仅限 RDE100.1) 注意: 扫描速度越快电池寿命越短	0.2 = 0.25 秒 0.5 = 0.5 秒 1.0 = 1.0 秒 (默认) 1.5 = 1.5 秒
P22	重置出厂设置	0 = OFF (默认) 1 = 重置
P23	软件版本信息	不可调
P78	控制行为	0 = 开/关, 1.0 K 1 = 开/关, 0.3 K 2 = TPI 快 3 = TPI 中 4 = TPI 慢 (默认)
P89	最大提前开启时间	0, 0.5, ... 24 小时 默认值: 0 小时
P90	最大提前关闭时间	0, 0.5, ... 6 小时 默认值: 0 小时

ZH

内置电池的旧电子设备的废弃处置

ZH



该设备是需要根据欧洲指令 2012/19/EU 进行处置的电子设备，不得作为生活垃圾处理。









- 通过为此目的提供的渠道处置该设备。
- 请遵守当地现行的所有法律法规。
- 废旧电池要丢弃到指定的收集点。

It Naudotojo instrukcija

RDE100.. – patalpos termostatas su kuriuo galėsite nustatyti tikslią patalpos temperatūrą tuo laiku kada to norite. Keletas nustatymų, parametų priskyrimo būdų jūsų individualiems poreikiams išpildyti.



1. Ekranas

-  Indikacija, kad reikia keisti bateriją (tik versijai su baterijų maitinimu)
-  Prieš už šalimo režimas (šildymas) aktyvus
-  Automatinis laiko režimas
-  Parodo ir nustato automatinį persijungimą pagal laiką
-  Komfortinis režimas
-  Taupymo režimas
-  Išeiti
-  Išorinis jėjimas aktyvuotas
-  Pastovios užduoties nustatymai
-  Dienos ir laiko nustatymai
-  Atostogų režimo nustatymai



Laikrodžio indikacija

am

Rytas: 12-valandų formatui

pm

Popietė: 12-valandų formatui



ALL

Patvirtinimas (OK)

°F

Patalpos temperatūra pagal Farenheitą

°C

Patalpos temperatūra pagal Celsijų



Nustatymų užraktas aktyvuotas

245

Patalpos temp atvaizdavimas, užduotos temp atvaizdavimas, tt



Šildymas įjungtas

1 2 3 4 5 6 7

Savaitės dienos
1 = Pirmadienis
7 = sekmadienis

0 6 12 18 24

Laiko grafa



Esama patalpos temperatūra

2. Valdymo režimo keitimas

3. Nustatyti

4. OK

5. Reikšmės mažinimas

6. Reikšmės didinimas

7. Baterijų laikiklis

Norite nustatyti laiką ir dieną?

nustatyti	Tęsti sekančiai:
ok	• Paspausti nustatyti ir pasirinkti 🕒
+	• Paspausti ok ir laiko grafa mirksės nustatymui
–	• Paspausti + arba – laiko nustatymui
rėžimas	• Paspausti ok patvirtinimui
	• Savaitės diena mirksės, paspausti + arba – numatytos dienos nustatymui
	• Paspausti ok reikšmės išsaugojimui
	• Paspausti rėžimas kad išeiti arba palaukite kol automatiškai išeis iš programavimo

LT





Norite užrakinti nustatymo mygtukus?

rėžimas	Paspausti ir laikyti rėžimas ne mažiau 7 sekundžių užrakto aktyvavimui. Atrakinimui pakartoti. Įrenginys funkcionuos pagal užduotą programą, bet jokie pakeitimai negalimi kol mygtukai yra užrakinti.
----------------	--

Ar jūsų patalpoje per karšta/per šalta?

+ – ok nustatyti rėžimas	Paspausti + arba – kad padidinti arba sumažinti patalpos temperatūros nustatymą per 0.5 °C / 1 °F. Tęsti sekančiai: <ul style="list-style-type: none">• Paspausti + arba – kad laikinai pakeisti nustatymą Šis pakeitimas atsistato po valdymo režimo pasikeitimo.• Paspausti ok, nustatyti arba rėžimas reikšmės išsaugojimui arba palaukite kol automatiškai išeis iš programavimo• Nustatymų užrakinimui naudokite parametrus P06 ir P08.
---	--

Ar jūs norite pakeisti valdymo režimą?

<p>rėžimas</p> <p>!</p>	<p>Patalpos termostatas palaiko komfortinį režimą, taupymo režimą ir automatinį laiko režimą. Pakeisti režimą galite paspausdami mygtuką rėžimas.</p> <p> Komfortinis režimas yra ne pertraukiamas (24 h) komforto pasirinkimas. Pasirinkus šį režimą palaikoma komforto temperatūrą nepertraukiamai, netaikant jokių laiko programų perjungimų. Tai gali būti taikoma tada kai esate patalpoje.</p> <p> Taupymo režimas yra ne pertraukiamas (24 h) taupymo pasirinkimas. Pasirinkus šį režimą palaikoma taupymo temperatūrą nepertraukiamai, netaikant jokių laiko programų perjungimų. Tai gali būti taikoma tada kai patalpoje nieko nėra, pavyzdžiui naktį.</p> <p> AUTO Tuo metu kai parinktas automatinis laiko režimas, režimai (komfortinis, taupymo) keičiasi automatiškai pagal nustatyta laiko programą.</p> <p>Pastaba: Prieš už šalimo režimo funkcija visuomet aktyvi. Jei temperatūra patalpoje nukris žemiau iki 5 °C, termostatas automatiškai įjungs šildymą .</p>
---------------------------------------	--



Ar jūs norite nustatyti temperatūros nustatymus?

<p>nustatyti</p> <p>ok</p> <p>+</p> <p>–</p> <p>rėžimas</p> <p>!</p>	<p>Paspausti nustatyti ir pasirinkti </p> <ul style="list-style-type: none">• Paspausti ok patvirtinimui• Paspausti rėžimas, kad pasirinkti komfortinį arba taupymo režimą• Paspausti + arba – kad pasirinkti nuolatinį temperatūros nustatymą.• Paspausti ok patvirtinimui <p>Paspausti rėžimas, kad išeiti arba palaukite kol automatiškai išeis iš programavimo</p> <p>Pastaba: Šie nuolatiniai temperatūros nustatymai naudojami automatinio laiko režimo metu.</p>
--	---

Energijos taupymas neprarandant komforto

- Pasirinkite **automatinį laiko režimą** šildymo periodu ir nustatykite laiko programą pagal jūsų būvio namuose laiką
- Pasirinkite **taupymo** režimą arba **atostogų** režimą kai namuose nebūnate ilgesnį laiką

Ar jūs norite nustatyti atostogų režimą?

<p>nustatyti ok + - režimas</p> <p>!</p>	<p>Naudokite atostogų režimą nustatant patalpos termostatą fiksuotai pažemintai temperatūrai kai jūsų nėra namuose.</p> <ul style="list-style-type: none">• Paspausti nustatyti ir pasirinkti • Paspausti ok patvirtinimui• Paspausti + ar - kad nustatyti temperatūrą• Paspausti ok patvirtinimui• Paspausti + ar - kad nustatyti atostogų dienų skaičių (pastaba: 0 = atostogų režimas išjungtas)• Paspausti ok nustatymo išsaugojimui• Kai yra aktyvuotas atostogų režimas , numatomas atostogų dienų skaičius yra atvaizduojamas ant displejaus <p>Pastaba: Jei paspausite režimas kai yra aktyvuotas atostogų režimas, ši funkcija išsijungia ir  simbolis nebeatvaizduojamas.</p> <p>Jei komfortinis ir taupymo režimų reikšmės yra užrakintos, tai žemiausia iš šių reikšmių yra atostogų režimo nustatymo temperatūros reikšmė. Jūs galite nustatyti temperatūrą nuo 5 °C iki žemiausios užrakintos temperatūros reikšmės.</p>
--	---

LT

Ar jūs norite nustatyti individualų lako režimą?

Pvz1: Laiko grafikas individualioms dienoms (P11=0)

nustatyti
ok
+
-
režimas

Jūs galite priskirti komfortinį režimą arba taupymo režimą intervalais kas 15 minučių visos paros bėgyje. Nuo 0:00 iki 24:00 valandų bėgyje jūs galite pasirinkti darbo režimą pasirinktomis dienomis.

Pavyzdys:

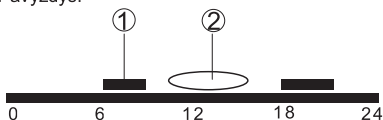

- ① Pažymėta (paryškinta) juosta: valdo komfortinę temperatūrą
- ② Nepažymėta: valdo taupymo režimo temperatūrą

Tuo metu kai pasirinktas automatinis laiko režimas, pasikeitimas tarp darbo režimų vyksta pagal jūsų pasirinktą ir išsaugotą nustatymą.



Tęsti sekančiai:

- 1) Paspausti **nustatyti** ir pasirinkti  AUTO.
- 2) Paspausti **ok** patvirtinimui.
- 3) Rodomas laiko grafikas dienai 1 (pirmadienis) .
- 4) Paspausti **+** arba **-** dienos pasirinkimui, nuo 1 (pirmadienis) iki 7 (sekmadienis).
- 5) Paspausti **ok** pasirinktos dienos patvirtinimui ir laiko programos priskirimo pradžia.

Žingsniai programavimo metu:



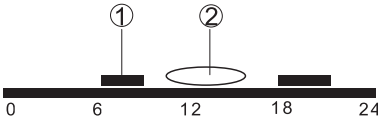

- 6) Paspausti **režimas** valdymo režimo parinkimui, (komfortinis arba taupymo) arba
- 7) Paspausti **+** arba **-** kad parinkti laiko grafiką kas 15 minučių pasirinktam režimui.
- 8) Paspausti **ok** pasirinktos laiko programos išsaugojimui.
- 9) Pakartoti žingsnius 4-8 visoms reikiams dienoms (jei reikia); arba
- 10) Paspausti **režimas** kad išeiti arba palaukite kol automatiškai išeis iš programavimo

Pvz 2: Laiko grafiko nustatymas vienodai 7 dienoms (P11=1)

<p>nustatyti ok + - rėžimas</p>	<p>Jūs galite priskirti vienodą laiko grafiką visoms 7 (septynioms) savaitės dienoms vienu metu. Pavyzdys:</p>  <p>0 6 12 18 24</p> <p>① Pažymėta (paryškinta) juosta: valdo komfortinę temperatūrą</p> <p>② Nepažymėta: valdo taupymo režimo temperatūrą</p> <p>Tęsti sekančiai:</p> <ol style="list-style-type: none">1) Pasirinkti parametą (P11=1). Prašome vadovautis aprašymu " Ar jūs norite pakeisti nustatymus?".2) Paspausti nustatyti ir pasirinkti  AUTO.3) Paspausti ok patvirtinimui.4) Atvaizduojama laiko programa periodui 1 (pirmadienis) - 7 (sekmadienis)5) Paspausti ok laiko programos priskirimo pradžiai. <div data-bbox="279 863 932 1042"><p>Žingsniai programavimo metu:</p><ol style="list-style-type: none">6) Paspausti rėžimas valdymo režimo parinkimui, (komfortinis arba taupymo) arba7) Paspausti + arba - kad parinkti laiko grafiką kas 15 minučių pasirinktam režimui.</div> <ol style="list-style-type: none">8) Paspausti ok pasirinktos laiko programos išsaugojimui.9) Paspausti rėžimas kad išeiti arba palaukite kol automatiškai išeis iš programavimo
---	--

LT

Pvz 3: Laiko grafiko nustatymas 5-2 dienoms (P11=2)

nustatyti ok + - rėžimas	<p>Jūs galite priskirti laiko grafiką nuo pirmadienio iki penktadienio ir nuo šeštadienio iki sekmadienio vienu metu.</p> <p>Pavyzdys: ① ②</p>  <p>0 6 12 18 24</p>	
LT	<p>① Pažymėta (paryškinta) juosta: valdo komfortinę temperatūrą</p> <p>② Nepažymėta: valdo taupymo režimo temperatūrą</p> <p>Tęsti sekančiai:</p> <ol style="list-style-type: none">1) Pasirinkti parametras (P11=2 Prašome vadovautis aprašymu " Ar jūs norite pakeisti nustatymus?").2) Paspausti nustatyti ir pasirinkti  AUTO.3) Paspausti ok patvirtinimui.4) Atvaizduojama laiko programa periodui 1 (pirmadienis) - 5(penktadienis).5) Paspausti + arba - dienos pasirinkimui, 1 (pirmadienis) - 5(penktadienis) arba 6 (šeštadienis) - 7 (sekmadienis).6) Paspausti ok pasirinktos dienos patvirtinimui ir laiko programos priskirimo pradžiai.	
	<p>Žingsniai programavimo metu:</p> <ol style="list-style-type: none">7) Paspausti rėžimas valdymo režimo parinkimui, (komfortinis arba taupymo) arba8) Paspausti + arba - kad parinkti laiko grafiką kas 15 minučių pasirinktam režimui.	
	<ol style="list-style-type: none">9) Paspausti ok pasirinktos laiko programos išsaugojimui.10) Pakartoti žingsnius 5-9 visoms reikiamoms dienoms (jei reikia); arba11) Paspausti rėžimas kad išeiti arba palaukite kol automatiškai išeis iš programavimo	

Gamyklinis standartas 7-dienų laiko režimui

Standartinės reikšmės	Diena/dienos	Komfortinis režimas	Taupymo režimas
	Mo (1) – Fr (5)	6:00 – 8:00 hr 17:00 – 22:00 hr	22:00 – 6:00 hr 8:00 – 17:00 hr
	Sa (6) – Su (7)	7:00 – 22:00 hr	22:00 – 7:00 hr

Ar pas jus ant displejaus atsirado toks simbolis  ?

(Tik baterijomis maitinamiems prietaisams)

Simbolis  atsiranda tada kai baterijos išsikrauna. Pakeiskite jas dvejomis naujomis alkaline baterijomis AAA modelio.

LT

Tęsti sekant:iai:

Įsigykite 2 naujas alkaline baterijas AAA modelio

- Išimkite baterijų laikiklį, po to išimkite iš jo senas baterijas, įstatykite naujas baterijas ir įstatykite baterijų laikiklį atgal neviršijant 1.5 minutės.
- Užtikrinkite, kad panaudotos baterijos būtų tinkamai utilizuotos.

Ar jūs norite pakeisti nustatymus?

+ – ok rėžimas	<p>Jeigu norite pakeisti paslėptus nustatymus, tęskite sekant:iai :</p> <ul style="list-style-type: none">• Paspausti + ir – kartu 5 (penkias) sekundes• Atlaskite mygtukus kai parametras "P01" bus rodomas apatinėje ekrano dalyje• Paspausti + arba – perėjimui į reikiamo parametro nustatymą• Paspausti ok parametro nustatymo keitimui• Paspausti + arba – reikšmės pakeitimui• Paspausti ok pasirinktos reikšmės patvirtinimui• Paspausti rėžimas kad išeiti arba palaukite kol automatiškai išeis iš programavimo
---	--

Parametrų sąrašas

Parametro nr.	Aprašas	Nustatymo ribos (standartas)
P01	Laiko formatas	1 = 24:00 valandos (standartas) 2 = 12:00 AM/PM
P02	Pasirinkimas °C ar °F	1 = °C (standartas) 2 = °F
P03	Displėjuje atvaizduojama temperatūra	1 = patalpos temperatūra (standartas) 2 = užduota temperatūra
P04	Temperatūros jutiklio koregavimas	-3...3 °C žingsnis 0.5 °C (-6...6 °F, žingsnis 1 °F) Standartas: 0 °C
P06	Komforto nustatymo užrakinimas	0 = OFF (standartas) 1 = ON → užrakintas priklausomai nuo užduoto nustatymo
P08	Taupymo nustatymo užrakinimas	0 = OFF (standartas) 1 = ON → užrakintas priklausomai nuo užduoto nustatymo
P09	Zirzeklis	0 = OFF 1 = ON (standartas)
P10	Prieš užšaliminio režimo ženklą rodomas ekrane	0 = OFF (standartas) 1 = ON
P11	Laiko programos nustatymas auto režimo programavimui	0 = visos dienos atskirai (standartas) 1 = 7 dienos 2 = 5/2 dienos
P12	Periodinis siurblio prasukimas	0 = OFF (standartas) 1 = ON

LT

P14	X1 išorinis jėjimas (tik su RDE100.1)	0 = jėjimas nenaudojamas 1 = išorinis jutiklis 2 = skaitmenis jėjimas
P15	Tem peratūros ribojimas (tik su RDE100.1)	0 = OFF (standartas) 1 = ON
P16	Maksimalios temperatūros ribojimas šildomoms grindims (tik su RDE100.1)	25...60 °C, žingsnis 1 °C arba 77...140 °F, žingsnis 1 °F Standartas: 30 °C
P17	Lango kontakto funkcija (tik su RDE 100.1)	0 = Normaliai atviras kontaktas (standartas) 1 = Normaliai uždaras kontaktas
P21	Mygtukų skanavimo laikas (tik su RDE100.1) Pastaba: trumpesni skanavimo intervalai trumpina baterijų darbo laiką	0.2 = 0.25 s 0.5 = 0.5 s 1.0 = 1.0 s (standartas) 1.5 = 1.5 s
P22	Atkurti gamyklinius parametrus	0 = OFF (standartas) 1 = atkurti
P23	Programines versijos modifikacija	Pakeitimai negalimi
P78	Valdymo elgsena	0 = įjungta/išjungta, 1.0 K 1 = įjungta/išjungta, 0.3 K 2 = TPI greitas 3 = TPI vidutinis 4 = TPI lėtas (standartas)
P89	Maksimalus išplėstinio paleidimo laikas	0, 0.5,...24 val. Standartas: 0 val.
P90	Maksimalus išplėstinio uždarymo laikas.	0, 0.5,...6 val. Standartas: 0 val.

LT

fi Käyttöohjeet

RDE100.. – Huonetermostaatti, millä voit säätää tilojen lämpötilaa. Termostaatissa useita vaihtoehtoja säätää tilojen lämpötila parhaalla mahdollisella tavalla.



1. Näyttö

 Vaihda paristo
(paristoversiossa)



Jäätymissuojaus
(lämmitys)
aktiivinen



AUTO

Aikaohjelma

Aikaohjelmien
muokkaus



Mukavuus



Säästötila



mode

Poistu



Ulkoinen tulo(LT
mitt)



Asetuspiste



Päivä/aika
asetukset



Loma-ajan
asetukset



Klo. Aika

am

Aamupäivä: 12-h.

pm

Iltapäivä: 12-h.



ALL

Tallenna



Huone LT Fahrenheit



Huone LT Celsius



Lukttu



Näyttö, huone LT,
asetuspiste, ...



Lämmitys: ON

Viikonpv. 1 =

Maanantai

7 =

Sunnuntai



Aika ohj. Palkki



Lämpötila

FI

2. Vaihda käyttötila

3. Aseta/Tallenna

4. OK

5. Pienennä, arvoa -

6. Lisää, arvoa +

7. Pariston pidike

Aika/Päivä asetukset

aset	Asetukset
ok	<ul style="list-style-type: none">• Paina aset ja valitse 🕒
+	<ul style="list-style-type: none">• Paina ok, klo aika alkaa vilkkua, voit tehdä muutokset
-	
tila	<ul style="list-style-type: none">• Paina + tai - muuttaaksesi klo. aikaa• Paina ok vahvistaaksesi muutokset• Viikonpäivät, vilkkua, paina + tai - valitaksesi pvm.• Paina ok vahvistaaksesi muutokset• Paina ok poistuaksesi, tai odota että laite palaa autom. perustilaan

FI





Painikkeiden lukitus

aset	Paina aset painiketta väh. 7 sek. aktivoiaksesi näppäimistölukon . Vapautetaan samalla tavalla. Termostaatti toimii normaalisti vaikka näppäimistö on lukittu, muutoksia ei voi tehdä.
-------------	---

Huonetila liian kylmä/lämmin?

+	Painamalla + tai - painikkeita voit säätää huone lämpötilaa 0.5 °C / 1 °F.
-	
ok	<ul style="list-style-type: none">• Paina + tai - painiketta säätääksesi lämpötilaa. Asetus palaa perus astukseen kun lämmitys tilaa muutetaan (mukavuus/säästö).
aset	
tila	<ul style="list-style-type: none">• Paina ok, aset tai tila tallentaaksesi muutokset, tai odota että laite palaa autom perustilaan.• Perusasetusten, LT muutos, parametrit P06 ja P08.

Lämmitystilän muutos (Muk./Säästö)?

tila	<p>Termostaatissa on 3-lämmitys tilaa, Mukavuus, Säästö ja Auto tilat.Vaihto tapahtuu tila painikkeella.</p> <p> Mukavuus tila, lämmitys aina mukavuusasetusten mukaisesti.</p> <p> Säästötila, lämmitys aina säästötilan mukaisesti.</p> <p> Aika-ohjelma, lämmitys aika-ohjelman mukaisesti.</p> <p>! HUOM: Jäätymissuojaus on aina aktiivisena, lämmitys aktivoituu kun huone LT laskee alle 5 °C, .</p>
-------------	---

FI



LT asetusarvojen muutos?

asetta ok + - tila	<ul style="list-style-type: none">• Paina asetta ja valitse • Paina ok• Paina tila valitse käyttötila, mukavuus tai säästö• Paina + tai - säätääksesi asetusarvoa.• Paina ok• Paina tila tallentaaksesi muutokset, tai odota että laite palaa autom perustilaan. <p>! HUOM: Näitä asetuksia käytetään kun laite on Autom.tilassa</p>
---	---

Energian säästöjä, mukavuudesta tinkimättä

- Käytä aikaohjelmaa lämmityskaudella ja muokkaa ne sopiviksi käyttötarkoituksen mukaan (kotona/poissa)
- Käytä säästötilaa loma-aikana tai kun olet pitemmän aikaa poissa.

Loma-ajan asetukset

asetta	Loma-ajan asetuksista voit säätää lämpötilat loma-ajaksi
ok	
+	• Paina asetta ja valitse 
-	• Paina ok
tila	• Paina + tai - muuttaaksesi LT as.arvoa
	• Paina ok vahv. muutokset
	• Paina + tai - määrittääksesi lomapäivät (Huom: 0 = loma-asetukset EI Käyössä)
	• Paina ok = vahv. muutokset
	• Kun loma-aika asetus on aktivoitu, jäljellä olevat pvmt näkyy näytöllä.
!	HUOM: Mikäli painat tila painiketta kun loma-aika asetukset ovat aktiiviset, laite palaa perustilaan ja 

FI

Oman aikaohjelman tekeminen?

Optio 1: Aika ohjelma, kaikille päiville omat asetukset (P11=0)

asetta
ok
+
-
tila

Aikaohjelma 15 min. aikajaksoilla, Mukavuus tai säästö.

Esimerkki:

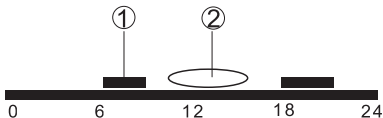

① Näkyvä palkki: Mukavuus LT

② Ei palkkia: Säästö LT

Kun Auto toiminto on käytössä, säädin säätää lämpötilaa aika-ohjelman mukaan.



Aikaohjelman tekeminen:

- 1) Paina **asetta** ja valitse  AUTO.
- 2) Paina **ok**.
- 3) Aika-ohjelma maanantaille(1) ilm.näyttöön.
- 4) Paina **+** tai **-** valitaksesi päivän, maanantai(1) Sunnuntai(7).
- 5) Paina **ok** valitaksesi päivän ja muokkaa aika-ohjelmaa.

Mukavuus/säästötilat:

- 6) Paina **tila** painiketta valitaksesi mukavuus/säästötilan.**Tai**
- 7) Paina **+** tai **-** painiketta säätääksesi aika-ohjelmaa, min.porras 15 min.
- 8) Paina **ok** tallentaaksesi muutokset.
- 9) Toista kohdat 4-8 muille päiville (mikäli tarvetta); tai
- 10) Paina **tila** painiketta tai odota että termostaatti palaa auto-asetuksiin.

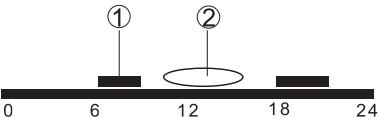
Optio 2: Sama aika-ohjelma kaikille päiville (P11=1)

asetä ok + - tila	<p>Sama aika-ohjelma kaikille päiville Esim:</p>  <p>① Näkyvä palkki: Mukavuus LT ② Ei palkkia: Säästö LT</p> <p>Toimi seuraavasti:</p> <ol style="list-style-type: none">1) Aseta parametri (P11=1). Mene valikkoon "Haluatko vaihtaa asetuksia".2) Paina asta ja valitse  AUTO.3) Paina ok.4) Aika-ohjelma Ma-Su Ma (1) - Su (7) ilmesty näyttöön.5) Paina ok tehdäkseksi muutoksia. <p>Mukavuus/säästötilat:</p> <ol style="list-style-type: none">6) Paina tila painiketta valitaksesi mukavuus/säästötilan. Tai7) Paina + tai - painiketta säätääksesi aika-ohjelmaa, min.porras 15 min <ol style="list-style-type: none">8) Paina ok tallentaaksesi muutokset.9) Paina tila painiketta tai odota että termostaatti palaa auto-asetuksiin.
--	---

3, Aika-ohjelmat 5/2 (Ma-Pe/La-Su) (P11=2)

asetta
ok
+
-
tila

Voit asettaa aika-ohjelmat Ma-Pe ja La-Su.

Esim:

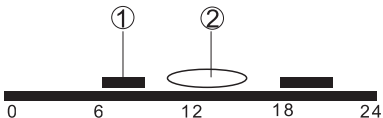

① Näkyvä palkki: Mukavuus lämpötila

② Ei palkkia: Säästö lämpötila

Toimi seuraavasti:

- 1) Aseta parametri (P11=2). Mene valikkoon "**Haluatko vaihtaa asetuksia**".
- 2) Paina **asetta** ja valitse  AUTO.
- 3) Paina **ok**.
- 4) Aika-ohjelma Ma(1) - pe(5) on näytöllä.
- 5) Paina **+** tai **-** aika-ohjelmaa, Ma (1) - Pe(5) Tai LA (6) - Su (7).
- 6) Valitse aika-ohjelma mitä haluat muokata.

Aika-ohjelma:

- 7) Valitse käyttötila, (Mukavuus tai Säästö) **tai**
- 8) Paina **+** tai **-** muokkaa aika-ohjelmaa, min. Asetus 15 min.
- 9) Paina **ok** tallentaaksesi aika-ohjelman.
- 10) Toista kohdat 5-9 tarvittaessa; tai
- 11) Paina **tila** painiketta tai odota että termostaatti palaa Auto asetuksiin.

Tehdas-aset. 7- päivän aika-ohjelma

Tehdas aset.	Päivät	Mukavuus	Säästö
	Ma (1) – Pe (5)	6:00 – 8:00 h 17:00 – 22:00 h	22:00 – 6:00 h 8:00 – 17:00 h
	La (6) – Su (7)	7:00 – 22:00 h	22:00 – 7:00 h

Mikäli pariston kuva ilmestyy näyttöön?

(Vain paristoversio)

Pariston kuva  ilmestyy näyttöön mikäli paristo on loppumassa. Vaihda uudet paristot, malli AAA. Toimi seuraavasti.

FI

- Hanki uudet alkali paristot, malli AAA
- Avaa pariston pidike, vaihda paristot 1,5 min aikana että tehdyt muutokset säilyvät termostaatin muistissa.
- Paristot ovat ongelmajätettä, huolehdi että ne hävitetään asianmukaisesti.

Tehdas asetustem muuttaminen?

+ – ok tila	Tehdas asetusten muuttaminen: <ul style="list-style-type: none">• Paina + ja – yhtäaikaan väh. 5 sek.• Vapauta painikkeet ja parametri "P01" ilmestyy näytölle• Paina + tai – valitaksesi mitä parametria haluat muokata• Paina ok muokataksesi parametria• Paina + tai – vaihtaaksesi asetusarvoa• Paina ok vahvistaaksesi muutoksen• Paina tila tallentaaksesi muutokset, tai odota että laite palaa autom perustilaan.
--	--

Parametri lista

Parametri no.	Kuvaus	Tehdasastukset
P01	Ajan muoto	1 = 24:00 h.(tehdasas.) 2 = 12:00 AP/IP
P02	LT valinta °C tai °F	1 = °C (tehdasas.) 2 = °F
P03	Näytön LT	1 = Huone LT (tehdasas.) 2 = asetuspiste
P04	Huone-anturin kalibrointi	-3...3 °C muutos 0.5 °C (-6...6 °F, muutos 1 °F) Tehdasas: 0 °C
P06	Mukavuustilan lukitus	0 = Ei käytössä (tehdasas.) 1 = Käytössä → lukittu
P08	Säästötilan lukitus	0 = Ei käytössä (tehdasas.) 1 = Käytössä → lukittu
P09	Summeri	0 = Ei käytössä 1 = Käytössä (tehdasas)
P10	Näytä jäätymissuoj. kuva	0 = Ei käytössä (tehdasas.) 1 = Käytössä
P11	Aikaohjelma	0 = Kaikille oma ohj. (tehdasas) 1 = Kaikki 7 pv. 2 = 5/2 päivät
P12	Pumpun vuor.käyttö	0 = Ei käytössä (tehdasas.) 1 = Käytössä

P14	X1 LT tulo(vain RDE100.1)	0 = Ei 1 = Anturi 2 = Digit.tulo
P15	LT rajoitus (vain RDE100.1)	0 = Ei käytössä (tehd.as.) 1 = ON
P16	Max LT rajoitus lattialämmityksessä (vain RDE100.1)	25...60 °C, porras 1 °C tai 77...140 °F, porras 1 °F Tehdasas.: 30 °C
P17	Ikkunakytkin (vain RDE 100.1)	0 = NO (tehdasas) 1 = NC
P21	Painikkeiden luku-aika (RDE100.1)	0.2 = 0.25 s 0.5 = 0.5 s 1.0 = 1.0 s (tehdasas) 1.5 = 1.5 s
P22	Palauta tehdas-as	0 = Ei (tehdasas) 1 = Palauta
P23	Ohjelmaversio	Ei voi muuttaa
P78	Säätökäyttäytyminen	0 = auki/kiinni, 1.0 K 1 = auki/kiinni, 0.3 K 2 = TPI nopea 3 = TPI normaali 4 = TPI hidas (tehdasas.)
P89	Suurin ennakoita käynnistysaika	0, 0.5,...24 tuntia Tehdasas.: 0 tuntia
P90	Suurin ennakoita sulkemisaika	0, 0.5,...6 tuntia Tehdasas.: 0 tuntia

Paristokäyttöisen elektroniikkaromun hävittäminen

FI



Laite hävitetään elektroniikkaromuna EU-direktiivin 2012/19/EU mukaisesti eikä sitä saa hävittää kotitalousjätteen mukana.

- Hävitä laite tarkoituksenmukaisen kierrätyspisteen kautta.
- Noudata paikallista ja voimassaolevaa lainsäädäntöä.
- Vie käytetyt paristot niille tarkoitettuihin keräyspisteisiin.

pl Instrukcja obsługi

RDE100.. – pomieszczeniowe regulatory temperatury które w łatwy sposób umożliwiają zapewnienie optymalnej temperatury w pomieszczeniu. Do dyspozycji jest kilka indywidualnie nastawianych programów ogrzewania. Można skorzystać z fabrycznych nastaw urządzenia, bądź też dopasować je do własnych potrzeb.



1. Wyświetlacz

	Symbol sygnalizujący konieczność wymiany baterii (tylko przy zasilaniu baterijnym)		Wyświetlacz czasu
	Tryb pracy Ochrona	am pm	Przedpołudnie: format 12 godzinny Popołudnie: format 12 godzinny
	Tryb pracy Automatyczny		Zatwierdzenie wyboru
AUTO	Automatyczny program czasowy	ALL	
	Tryb pracy Podgląd i ustawienia Automatycznego programu czasowego	°F	Temperatura w stopniach Fahrenheit'a
	Tryb pracy Komfort	°C	Temperatura w stopniach Celsius'a
	Tryb pracy Ekonomiczny		Blokada przycisków aktywna
	Wyjście	245	Wyświetlanie temperatury w pomieszczeniu , wartości zadanej
	Symbol informujący o aktywności wejścia zewnętrznego		Symbol informujący o załączeniu ogrzewania
	Ustawienie wartości zadanej na stałe	1 2 3 4 5 6 7	Dzień tygodnia 1 = poniedziałek 7 = niedziela
	Ustawienia daty i godziny		Pasek czasu
	Ustawienia trybu wakacyjnego		Symbol informujący o wyświetlaniu aktualnej temperatury w pomieszczeniu

2. Przycisk do zmiany trybu pracy

3. Ustaw

4. Zatwierdź

5. Przycisk do zmniejszania wartości

6. Przycisk do zwiększania wartości

7. Baterie

Czy chcesz ustawić dzień tygodnia i godzinę?

ustaw zatwierdź + - zmiana trybu pracy	Sposób postępowania: <ul style="list-style-type: none">• Naciśnij przycisk ustaw i wybierz symbol ⌚• Naciśnij przycisk zatwierdź Wyświetlony czas zacznie migać.• Naciśnij przycisk + lub - aby wprowadzić aktualną godzinę.• Naciśnij przycisk zatwierdź• Wyświetlony dzień tygodnia zacznie miga, wciśnij przycisk + lub - aby ustawić dzień tygodnia.• Naciśnij przycisk zatwierdź• Naciśnij przycisk zmiany trybu pracy aby wyjść, lub zaczekaj aż regulator samoczynnie powróci do widoku głównego.
---	---

PL

Czy chcesz aktywować blokadę przycisków?





zmiana trybu pracy	Naciśnij przycisk zmiany trybu pracy przez przynajmniej 7 sekund aby aktywować blokadę przycisków. Aby odblokować, powtórz czynność. Blokada przycisków nie wpływa na działanie regulatora, natomiast wprowadzania zmian nie jest możliwe.
-----------------------------------	---

Czy w pomieszczeniach jest za zimno lub za gorąco?

+ - zatwierdź ustaw zmiana trybu	Aby zwiększyć lub zmniejszyć wartość zadaną temperatury w pomieszczeniu o 0.5 °C / 1 °F, postępuj następująco: <ul style="list-style-type: none">• Wciśnij przycisk + lub - aby zmienić wartość zadaną tymczasowo. Wprowadzone wartości zostaną automatycznie zresetowane przy najbliższym przełączeniu trybu pracy.• Wciśnij przycisk zatwierdź, ustaw lub zmiany
---	---

pracy	<p>trybu pracy by zapisać wartość lub zaczekać aż program automatycznie powróci do widoku głównego.</p> <ul style="list-style-type: none"> • Aby zablokować zmianę nastaw, użyj parametrów P06 i P08.
-------	---

Czy chcesz zmienić tryb pracy?

<p>zmiana trybu pracy</p> <p>PL</p> <p>!</p>	<p>Możesz wybierać trzy tryby pracy: Automatyczny program czasowy, Komfort lub Ekonomiczny. W celu przełączenia pomiędzy trybami pracy można użyć przycisku zmiany trybu pracy</p> <p> Tryb Komfort - stałe utrzymywanie wartości zadanej temperatury trybu Komfort . Zapewnia odpowiedni komfort w pomieszczeniach gdy budynek jest używany.</p> <p> Tryb Ekonomiczny - stałe utrzymywanie wartości zadanej temperatury trybu Ekonomicznego. Obniża zużycie energii gdy budynek nie jest używany, np. w nocy.</p> <p> AUTO W trybie Automatyczny program czasowy, przełączanie pomiędzy trybami Komfort i Ekonomiczny następuje zgodnie z ustawionym programem czasowym.</p> <p>Uwaga:</p> <p>Zabezpieczenie przeciwzamrożeniowe jest funkcją zawsze aktywną. Jeśli temperatura w pomieszczeniu spadnie poniżej 5 °C, regulator automatycznie załączy ogrzewanie, a na wyświetlaczu pojawi się symbol </p>
--	--

Czy chcesz ustawić wartość zadaną na stałe?

<p>ustaw zatwierdź + - zmiana trybu pracy</p> <p>!</p>	<ul style="list-style-type: none">• Naciśnij przycisk ustaw i wybierz symbol • Naciśnij przycisk zatwierdź• Naciśnij przycisk zmiany trybu pracy aby wybrać zmianę wartości zadanej trybu Komfort lub Ekonomicznego.• Naciśnij przycisk + lub - by zmienić wartość zadaną.• Naciśnij przycisk zatwierdź• Naciśnij przycisk zmiany trybu pracy aby zapisać wartość lub zaczekaj aż regulator samoczynnie wróci do widoku głównego. <p>Uwaga: Wartości wprowadzone w ten sposób są używane także w trybu Automatyczny program czasowy.</p>
--	--



PL



Rady jak oszczędzać nie rezygnując z komfortu



- W okresie grzewczym wybierz tryb pracy Automatyczny program czasowy i ustaw czas przełączenia dostosowany do Twoich nawyków użytkowania domu.
- Wybierz tryb Ekonomiczny lub tryb wakacyjny w czasie gdy budynek nie jest używany przez dłuższy czas.

Czy chcesz ustawić tryb wakacyjny?

ustaw zatwierdź	Używaj trybu wakacyjnego gdy nie używasz budynku.
+	• Naciśnij przycisk ustaw i wybierz symbol 
-	• Naciśnij przycisk zatwierdź
zmiana trybu pracy	• Naciśnij przycisk + lub - aby zmienić wartość zadaną trybu wakacyjnego
	• Naciśnij przycisk zatwierdź
	• Naciśnij przycisk + lub - aby zmienić liczbę dni podczas których aktywny będzie tryb wakacyjny (Uwaga: 0 = tryb wakacyjny wyłączony)
	• Naciśnij przycisk zatwierdź aby zapisać wartość.
	• Kiedy tryb wakacyjny jest aktywny, wyświetlana jest liczba pozostałych dni do końca działania trybu wakacyjnego.
!	Uwaga: Jeśli podczas aktywnego trybu wakacyjnego naciśniesz przycisk zmiany trybu pracy , zostanie on wyłączony. Symbol  nie będzie wyświetlany. Jeśli wprowadzanie zmian wartości zadanej temperatury obu trybów Komfort i Ekonomiczny jest zablokowane (parametry P06 i P08), to w trybie wakacyjnym ustawiona zostanie najniższa wartość zadana temperatury. W trybie wakacyjnym możesz ustawić temperaturę od 5 °C do najniższej zablokowanej wartości zadanej.

Czy chcesz wprowadzić swój własny program czasowy?

Opcja 1: Program czasowy z wyborem dni tygodnia (P11=0)

<p>ustaw zatwierdź + - zmiana trybu pracy</p>	<p>Możesz ustawić czas pracy w trybie Komfort lub Ekonomicznym z rozdzielczością 15 minut dla wybranego dnia tygodnia. Pasek czasu pozwala na ustalenie czasu pracy w każdym z trybów.</p> <p>Przykład:</p>  <p>0 6 12 18 24</p> <p>① Widoczne segmenty: tryb pracy Komfort ② Niewidoczne segmenty: tryb pracy Ekonomiczny</p> <p>Kiedy wybrany jest tryb pracy Automatyczny program czasowy, przełączanie następuje zgodnie ze zdefiniowanym programem czasowym.</p> <p>Postępuj następująco:</p> <ol style="list-style-type: none">1) Naciśnij przycisk ustaw i wybierz symbol .2) Naciśnij przycisk zatwierdź3) Program czasowy dla pierwszego dnia tygodnia jest wyświetlany – Pon (1)4) Naciśnij przycisk + lub - aby wybrać dzień tygodnia. Pon (1) – Nie (7).5) Naciśnij przycisk ok aby zatwierdzić i przejść do trybu ustalania czasu pracy. <div data-bbox="279 963 932 1135"><p>Podczas ustalania czasu pracy:</p><ol style="list-style-type: none">6) Naciśnij przycisk zmiany trybu pracy aby wybrać tryb Komfort lub Ekonomiczny.7) Naciśnij + lub - aby zwiększać lub zmniejszać czas z rozdzielczością 15 minut.</div> <ol style="list-style-type: none">8) Naciśnij zatwierdź aby zapisać program czasowy.9) Powtórz kroki 4-8 w celu wprowadzenia programów czasowych dla pozostałych dni.10) Naciśnij przycisk zmiany trybu pracy lub zaczekaj aż regulator samoczynnie powróci do widoku głównego.
--	--

Opcja 2: Program czasowy dla wszystkich 7 dni (P11=1)

ustaw
zatwierdź
+
-
zmiana
trybu
pracy

Możesz ustawić taki sam program czasowy dla wszystkich dni tygodnia.

Przykład:

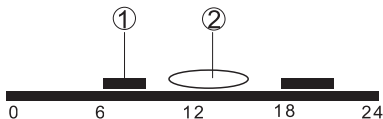

① Widoczne segmenty: praca w trybie Komfort

② Niewidoczne segmenty: praca w trybie Ekonomicznym



Postępuj następująco:

- 1) Ustaw parametr (P11=1). Zobacz "**Czy chcesz zmienić parametry?**".
- 2) Naciśnij przycisk **ustaw** i wybierz symbol .
- 3) Naciśnij przycisk **zatwierdź**
- 4) Program czasowy dla wszystkich dni tygodnia jest wyświetlany – Pon (1) – Nie (7)
- 5) Naciśnij przycisk **zatwierdź** aby przejść do trybu ustalania czasu pracy.

Podczas ustalania czasu pracy:

- 6) Naciśnij przycisk **zmiany trybu pracy** aby wybrać tryb Komfort lub Ekonomiczny
- 7) Naciśnij **+** lub **-** aby zwiększać lub zmniejszać czas z rozdzielczością 15 minut
- 8) Naciśnij **zatwierdź** aby zapisać program czasowy
- 9) Naciśnij przycisk **zmiany trybu pracy** lub zaczekaj aż regulator samoczynnie powróci do widoku głównego.

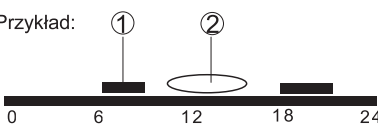
Opcja 3: 5 dni roboczych i 2 dni weekendowe (P11=2)

<p>ustaw zatwierdź + - zmiana trybu pracy</p>	<p>Możesz ustawić jeden program czasowy dla 5 dni roboczych i inny program czasowy na 2 dni weekendowe.</p> <p>Przykład:</p>  <p>① Widoczne segmenty: praca w trybie Komfort ② Niewidoczne segmenty: praca w trybie Ekonomicznym</p> <p>Postępuj następująco:</p> <ol style="list-style-type: none">1) Ustaw parametr (P11=2). Zobacz "Czy chcesz zmienić parametry?".2) Naciśnij przycisk ustaw i wybierz symbol  AUTO.3) Naciśnij przycisk zatwierdź4) Program czasowy dla dni roboczych jest wyświetlany: Pon (1) – Pią (5)5) Naciśnij przycisk + lub - aby wybrać dni robocze Pon (1) - Pią (5) lub dni weekendowe Sob (6) - Nie (7).6) Naciśnij przycisk zatwierdź aby przejść do trybu ustalania czasu pracy. <div data-bbox="279 899 932 1085" style="border: 1px solid black; padding: 5px;"><p>Podczas ustalania czasu pracy:</p><ol style="list-style-type: none">7) Naciśnij przycisk zmiany trybu pracy aby wybrać tryb Komfort lub Ekonomiczny.8) Naciśnij + lub - aby zwiększać lub zmniejszać czas z rozdzielczością 15 minut.</div> <ol style="list-style-type: none">9) Naciśnij zatwierdź aby zapisać program czasowy.10) Powtórz kroki 5-9 w celu wprowadzania programów czasowych dla dni weekendowych.11) Naciśnij przycisk zmiany trybu pracy lub zaczekaj aż regulator samoczynnie powróci do widoku głównego.
--	---

Ustawienia fabryczne programu czasowego

Ustawienia fabryczne	Dzień / Dni	Tryb Komfort	Tryb Ekonomiczny
	Pon (1) – Piąt (5)	6:00 – 8:00 17:00 – 22:00	22:00 – 6:00 h 8:00 – 17:00 h
	Sob (6) – Nie (7)	7:00 – 22:00 h	22:00 – 7:00 h

Czy pojawił się symbol na wyświetlaczu?

(Dotyczy tylko wersji zasilanej bateryjnie)

Symbol  oznacza, że baterie są wyczerpane. Wymień je na dwie nowe alkaliczne baterie typu AAA. Postępuj następująco:

- PL**
- Przygotuj 2 nowe baterie alkaliczne typu AAA 1,5 V
 - W przeciągu 1,5 minuty: Wyjąć oprawkę baterii z regulatora, usunąć z niej zużyte baterie i włożyć nowe, po czym ponownie włożyć oprawkę baterii do regulatora.
 - Zużyte baterie należy utylizować zgodnie z obowiązującymi przepisami.

Czy chcesz zmienić parametry?

+ – ustaw zmiana trybu pracy	<p>Jeśli chcesz zmienić parametry, postępuj następująco:</p> <ul style="list-style-type: none">• Naciśnij jednocześnie przyciski + i – i przytrzymaj przez 5 sekund, a następnie puść.• Wyświetlony zostanie parametr "P01" w dolnej części wyświetlacza .• Naciśnij przycisk + lub – aby przejść do wybranego parametru.• Naciśnij przycisk ok aby odblokować zmianę wartości parametru.• Naciśnij przycisk + lub – aby zmienić parametr.• Naciśnij przycisk zatwierdź• Naciśnij przycisk zmiany trybu pracy lub zaczekaj aż regulator samoczynnie wyjdzie z trybu zmiany parametrów.
---	---

Lista parametrów

Parametr	Opis	Opis nastaw
P01	Format wyświetlania czasu	1 = 24:00 godzinny (domyślny) 2 = 12:00 AM/PM
P02	Wybór °C lub °F	1 = °C (domyślnie) 2 = °F
P03	Standardowe wyświetlanie temperatury	1 = temperatura w pomieszczeniu (domyślnie) 2 = wartość zadana
P04	Kalibracja czujnika temperatury	-3...3 °C z krokiem 0.5 °C (-6...6 °F, z krokiem 1 °F) Domyślnie: 0 °C
P06	Zablokowanie zmiany nastawy trybu Komfort	0 = OFF (domyślnie) 1 = ON → zablokowana i równa wartości ustawionej na stałe dla tego trybu pracy
P08	Zablokowanie zmiany nastawy trybu Ekonomicznego	0 = OFF (domyślnie) 1 = ON → zablokowana i równa wartości ustawionej na stałe dla tego trybu pracy
P09	Sygnalizator akustyczny	0 = OFF 1 = ON (domyślnie)
P10	Wyświetlanie symbolu trybu Ochromy	0 = OFF (domyślnie) 1 = ON
P11	Ustawienie programu czasowego	0 = dla poszczególnych dni tygodnia (domyślnie) 1 = dla wszystkich 7 dni 2 = dla 5 dni roboczych / 2 dni weekendowych
P12	Funkcja okresowego uruchomienia pompy	0 = OFF (domyślnie) 1 = ON

PL

P14	X1 Wyjście zewnętrzne (tylko RDE100.1)	0 = Nieaktywne 1 = Czujnik wyniesiony 2 = Wejście cyfrowe
P15	Ograniczenie temperatury (tylko RDE100.1)	0 = OFF (domyślnie) 1 = ON
P16	Maks. Ograniczenie temperatury podłogi (tylko RDE100.1)	25...60 °C, z krokiem 1 °C lub 77...140 °F, z krokiem 1 °F Domyślnie: 30 °C
P17	Konfiguracja styku okiennego (tylko RDE 100.1)	0 = Styk NO (domyślnie) 1 = Styk NZ
P21	Okres pomiędzy skanowaniem przycisków regulatora (tylko w RDE100.1) Uwaga: im krótszy okres, tym krótsza żywotność baterii	0.2 = 0.25 s 0.5 = 0.5 s 1.0 = 1.0 s (domyślnie) 1.5 = 1.5 s
P22	Przywrócenie ustawień fabrycznych	0 = OFF (domyślnie) 1 = Przywróć ustawienia fabryczne
P23	Informacja o wersji oprogramowania	Nie ma możliwości wprowadzenia zmian
P78	Rodzaj regulacji	0 = Zał/Wył, 1.0K 1 = Zał/Wył, 0.3K 2 = TPI szybkie 3 = TPI średnie 4 = TPI wolne (domyślny)
P89	Wyprzedzenie zał. maks	0, 0.5,...24 h Domyślny: 0 h
P90	Wyprzedzenie wył. maks	0, 0.5,...6 h Domyślny: 0 h

PL

Utylizacja zużytego sprzętu elektronicznego i baterii



Zużyty sprzęt elektroniczny podlega obowiązkowi utylizacji w rozumieniu dyrektywy europejskiej 2012/19/UE i nie może być utylizowany razem z odpadami gospodarstwa domowego.

- Urządzenie należy oddać do utylizacji w specjalistycznej firmie.
- Należy przy tym przestrzegać lokalnych i aktualnie obowiązujących przepisów.
- Zużyte baterie należy zutylizować w odpowiednim punkcie odbioru tego typu odpadów.

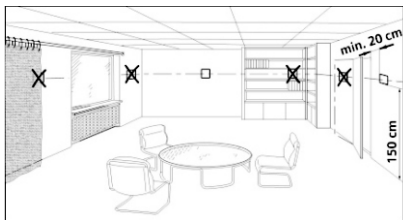

MT1429/201

Max. 1 x 2.5 mm²
Max. 2 x 1.5 mm²

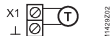

X1

⊥

MT1429/202

Wire
[mm²]

Max.
[m]

1.5

80



1.



2.

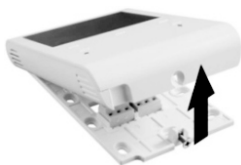

3.

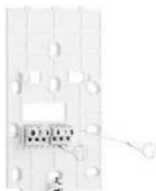

4.



5.



6.



RDE100

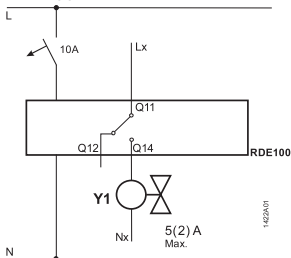

⚠ L-N AC 230 V

RDD100.1DHW / RDE100.1DHW

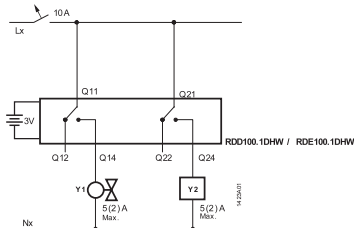

⚠ Lx-Nx 24...230 V

RDE100FP(Fil Pilote)

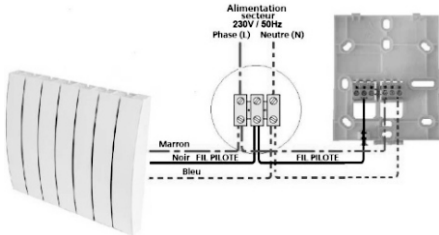

⚠ L-N AC 230 V

RDE100.1

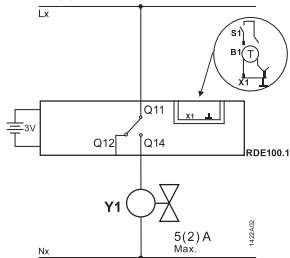

⚠ Lx-Nx 24...230 V



Max. 1.5 min.



1) www.siemens.com/HIT
(HIT start center)

2) "RDE"

3) (doc)

SIEMENS



RDE100..

- | | |
|--|---|
| en <i>Installation instructions</i> | de <i>Installationsanleitung</i> |
| fr <i>Instructions d'installation</i> | it <i>Istruzioni di montaggio</i> |
| el <i>Οδηγίες εγκατάστασης</i> | cs <i>Pokyny k instalaci</i> |
| hu <i>Telepítési leírás</i> | es <i>Instrucciones de montaje</i> |
| da <i>Installationsvejledning</i> | tr <i>Kurulum talimatları</i> |
| nl <i>Montage instructie</i> | zh <i>安装手册</i> |
| lt <i>Diegimo instrukcijos</i> | fi <i>Asennusohjeet</i> |
| pl <i>Instrukcja instalacji</i> | |

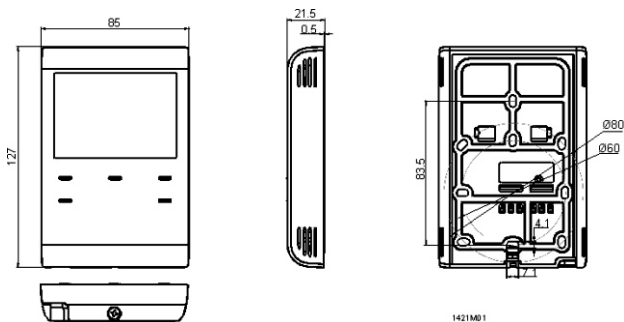

Siemens Building Technologies

• Siemens Switzerland Limited •